

Unità: mm

Numero d'Ordine Reference	R x D	L1	L2	L	d		Numero d'Ordine Reference	R x D	L1	L2	L	d	
2HRB 010 180 S06	0.5R X 1	1	18	60	6		2HRB 015 250 S06	0.75R X 1.5	1.5	25	65	6	
2HRB 010 200 S04	0.5R X 1	1	20	50	4		2HRB 015 300 S04	0.75R X 1.5	1.5	30	70	4	
2HRB 010 200 S06	0.5R X 1	1	20	60	6		2HRB 015 300 S06	0.75R X 1.5	1.5	30	70	6	
2HRB 010 220 S04	0.5R X 1	1	22	60	4		2HRB 015 350 S04	0.75R X 1.5	1.5	35	70	4	
2HRB 010 220 S06	0.5R X 1	1	22	65	6		2HRB 015 400 S04	0.75R X 1.5	1.5	40	80	4	
2HRB 010 250 S04	0.5R X 1	1	25	60	4		2HRB 016 060 S04	0.8R X 1.6	1.6	6	45	4	
2HRB 010 300 S04	0.5R X 1	1	30	70	4		2HRB 016 080 S04	0.8R X 1.6	1.6	8	45	4	
2HRB 012 040 S04	0.6R X 1.2	1.2	4	45	4		2HRB 016 120 S04	0.8R X 1.6	1.6	12	50	4	
2HRB 012 040 S06	0.6R X 1.2	1.2	4	50	6		2HRB 016 160 S04	0.8R X 1.6	1.6	16	50	4	
2HRB 012 060 S04	0.6R X 1.2	1.2	6	45	4		2HRB 016 200 S04	0.8R X 1.6	1.6	20	50	4	
2HRB 012 060 S06	0.6R X 1.2	1.2	6	50	6		2HRB 018 060 S04	0.9R X 1.8	1.8	6	45	4	
2HRB 012 080 S04	0.6R X 1.2	1.2	8	45	4		2HRB 018 080 S04	0.9R X 1.8	1.8	8	45	4	
2HRB 012 080 S06	0.6R X 1.2	1.2	8	50	6		2HRB 018 120 S04	0.9R X 1.8	1.8	12	50	4	
2HRB 012 100 S04	0.6R X 1.2	1.2	10	50	4		2HRB 018 160 S04	0.9R X 1.8	1.8	16	50	4	
2HRB 012 100 S06	0.6R X 1.2	1.2	10	50	6		2HRB 018 200 S04	0.9R X 1.8	1.8	20	50	4	
2HRB 012 120 S04	0.6R X 1.2	1.2	12	50	4		2HRB 020 040 S04	1R X 2	2	4	45	4	
2HRB 012 120 S06	0.6R X 1.2	1.2	12	50	6		2HRB 020 040 S06	1R X 2	2	4	50	6	
2HRB 012 160 S04	0.6R X 1.2	1.2	16	50	4		2HRB 020 060 S04	1R X 2	2	6	45	4	
2HRB 012 160 S06	0.6R X 1.2	1.2	16	60	6		2HRB 020 060 S06	1R X 2	2	6	50	6	
2HRB 012 200 S04	0.6R X 1.2	1.2	20	50	4		2HRB 020 080 S04	1R X 2	2	8	45	4	
2HRB 012 200 S06	0.6R X 1.2	1.2	20	60	6		2HRB 020 080 S06	1R X 2	2	8	50	6	
2HRB 012 240 S04	0.6R X 1.2	1.2	24	60	4		2HRB 020 100 S04	1R X 2	2	10	50	4	
2HRB 012 240 S06	0.6R X 1.2	1.2	24	65	6		2HRB 020 100 S06	1R X 2	2	10	50	6	
2HRB 014 060 S04	0.7R X 1.4	1.4	6	45	4		2HRB 020 120 S04	1R X 2	2	12	50	4	
2HRB 014 080 S04	0.7R X 1.4	1.4	8	45	4		2HRB 020 120 S06	1R X 2	2	12	50	6	
2HRB 014 120 S04	0.7R X 1.4	1.4	12	50	4		2HRB 020 140 S04	1R X 2	2	14	50	4	
2HRB 014 160 S04	0.7R X 1.4	1.4	16	50	4		2HRB 020 140 S06	1R X 2	2	14	50	6	
2HRB 015 030 S04	0.75R X 1.5	1.5	3	45	4		2HRB 020 160 S04	1R X 2	2	16	50	4	
2HRB 015 030 S06	0.75R X 1.5	1.5	3	50	6		2HRB 020 160 S06	1R X 2	2	16	60	6	
2HRB 015 040 S04	0.75R X 1.5	1.5	4	45	4		2HRB 020 180 S04	1R X 2	2	18	50	4	
2HRB 015 040 S06	0.75R X 1.5	1.5	4	50	6		2HRB 020 180 S06	1R X 2	2	18	60	6	
2HRB 015 060 S04	0.75R X 1.5	1.5	6	45	4		2HRB 020 200 S04	1R X 2	2	20	50	4	
2HRB 015 060 S06	0.75R X 1.5	1.5	6	50	6		2HRB 020 200 S06	1R X 2	2	20	60	6	
2HRB 015 080 S04	0.75R X 1.5	1.5	8	45	4		2HRB 020 220 S04	1R X 2	2	22	60	4	
2HRB 015 080 S06	0.75R X 1.5	1.5	8	50	6		2HRB 020 220 S06	1R X 2	2	22	65	6	
2HRB 015 100 S04	0.75R X 1.5	1.5	10	50	4		2HRB 020 250 S04	1R X 2	2	25	60	4	
2HRB 015 100 S06	0.75R X 1.5	1.5	10	50	6		2HRB 020 250 S06	1R X 2	2	25	65	6	
2HRB 015 120 S04	0.75R X 1.5	1.5	12	50	4		2HRB 020 300 S04	1R X 2	2	30	70	4	
2HRB 015 120 S06	0.75R X 1.5	1.5	12	50	6		2HRB 020 300 S06	1R X 2	2	30	70	6	
2HRB 015 140 S04	0.75R X 1.5	1.5	14	50	4		2HRB 020 350 S04	1R X 2	2	35	70	4	
2HRB 015 140 S06	0.75R X 1.5	1.5	14	50	6		2HRB 020 350 S06	1R X 2	2	35	75	6	
2HRB 015 160 S04	0.75R X 1.5	1.5	16	50	4		2HRB 020 400 S04	1R X 2	2	40	80	4	
2HRB 015 160 S06	0.75R X 1.5	1.5	16	60	6		2HRB 020 400 S06	1R X 2	2	40	80	6	
2HRB 015 180 S04	0.75R X 1.5	1.5	18	50	4		2HRB 020 450 S04	1R X 2	2	45	80	4	
2HRB 015 180 S06	0.75R X 1.5	1.5	18	60	6		2HRB 020 500 S04	1R X 2	2	50	90	4	
2HRB 015 200 S04	0.75R X 1.5	1.5	20	50	4		2HRB 025 080 S04	1.25R X 2.5	2.5	8	45	4	
2HRB 015 200 S06	0.75R X 1.5	1.5	20	60	6		2HRB 025 080 S06	1.25R X 2.5	2.5	8	50	6	
2HRB 015 220 S04	0.75R X 1.5	1.5	22	60	4		2HRB 025 100 S04	1.25R X 2.5	2.5	10	50	4	
2HRB 015 220 S06	0.75R X 1.5	1.5	22	65	6		2HRB 025 100 S06	1.25R X 2.5	2.5	10	50	6	
2HRB 015 250 S04	0.75R X 1.5	1.5	25	60	4		2HRB 025 120 S04	1.25R X 2.5	2.5	12	50	4	

Unità: mm

Numero d'Ordine Reference	R x D	L1	L2	L	d		Numero d'Ordine Reference	R x D	L1	L2	L	d	
2HRB 025 120 S06	1.25R X 2.5	2.5	12	50	6		2HRB 080 250 060	4R X 8	12	25	60	8	
2HRB 025 160 S04	1.25R X 2.5	2.5	16	50	4		2HRB 080 300 100	4R X 8	12	30	100	8	
2HRB 025 160 S06	1.25R X 2.5	2.5	16	60	6		2HRB 100 300 070	5R X 10	16	30	70	10	
2HRB 025 200 S04	1.25R X 2.5	2.5	20	60	4		2HRB 100 350 100	5R X 10	16	35	100	10	
2HRB 025 250 S04	1.25R X 2.5	2.5	25	60	4		2HRB 120 300 075	6R X 12	18	30	75	12	
2HRB 025 300 S04	1.25R X 2.5	2.5	30	70	4		2HRB 120 400 110	6R X 12	18	40	110	12	
2HRB 025 350 S04	1.25R X 2.5	2.5	35	70	4								
2HRB 025 400 S04	1.25R X 2.5	2.5	40	80	4								
2HRB 030 060 S06	1.5R X 3	3	6	50	6								
2HRB 030 080 S06	1.5R X 3	3	8	50	6								
2HRB 030 100 S06	1.5R X 3	3	10	50	6								
2HRB 030 120 S06	1.5R X 3	3	12	50	6								
2HRB 030 160 S06	1.5R X 3	3	16	60	6								
2HRB 030 200 S06	1.5R X 3	3	20	60	6								
2HRB 030 250 S06	1.5R X 3	3	25	65	6								
2HRB 030 300 S06	1.5R X 3	3	30	70	6								
2HRB 030 350 S06	1.5R X 3	3	35	75	6								
2HRB 030 400 S06	1.5R X 3	3	40	80	6								
2HRB 030 450 S06	1.5R X 3	3	45	90	6								
2HRB 030 500 S06	1.5R X 3	3	50	100	6								
2HRB 030 600 S06	1.5R X 3	3	60	100	6								
2HRB 030 650 S06	1.5R X 3	3	65	110	6								
2HRB 030 700 S06	1.5R X 3	3	70	110	6								
2HRB 040 080 S06	2R X 4	4	8	50	6								
2HRB 040 100 S06	2R X 4	4	10	50	6								
2HRB 040 120 S06	2R X 4	4	12	50	6								
2HRB 040 160 S06	2R X 4	4	16	60	6								
2HRB 040 200 S06	2R X 4	4	20	60	6								
2HRB 040 250 S06	2R X 4	4	25	65	6								
2HRB 040 300 S06	2R X 4	4	30	70	6								
2HRB 040 350 S06	2R X 4	4	35	75	6								
2HRB 040 400 S06	2R X 4	4	40	80	6								
2HRB 040 450 S06	2R X 4	4	45	90	6								
2HRB 040 500 S06	2R X 4	4	50	100	6								
2HRB 040 550 S06	2R X 4	4	55	100	6								
2HRB 040 600 S06	2R X 4	4	60	100	6								
2HRB 040 650 S06	2R X 4	4	65	110	6								
2HRB 040 700 S06	2R X 4	4	70	110	6								
2HRB 050 160 S06	2.5R X 5	6	16	60	6								
2HRB 050 200 S06	2.5R X 5	6	20	60	6								
2HRB 050 250 S06	2.5R X 5	6	25	70	6								
2HRB 050 300 S06	2.5R X 5	6	30	75	6								
2HRB 050 400 S06	2.5R X 5	6	40	80	6								
2HRB 050 450 S06	2.5R X 5	6	45	90	6								
2HRB 050 500 S06	2.5R X 5	6	50	100	6								
2HRB 050 600 S06	2.5R X 5	6	60	100	6								
2HRB 050 650 S06	2.5R X 5	6	65	110	6								
2HRB 050 700 S06	2.5R X 5	6	70	110	6								
2HRB 060 150 S06	3R X 6	10	15	55	6								
2HRB 060 300 S06	3R X 6	10	30	110	6								

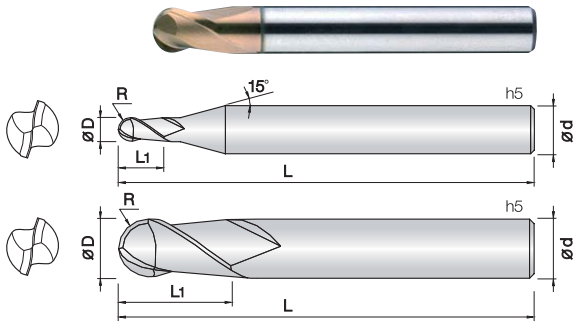

- **Fresa per acciai bonificati e temprati (HRc65)**
- Ottima resistenza all'usura grazie al nuovo rivestimento PVD a base Si.
- Elevata tolleranza del filo tagliente.
- Lunghezza ridotta per utilizzo con mandrini a calettamento.
- Prestazioni eccellenti in alta velocità garantite dal metallo duro Ultra Micrograna (0,2 µm).
- **Fraise pour aciers alliés et trempés jusqu'à 62HRc de dureté.**
- Excellent contre l'usure rapide grâce au revêtement PVD à base de Si
- Tolérances ultra précise de l'arête de coupe.
- Réduction des vibrations grâce à la longueur réduite de coupe.
- Tolérances élevées du diamètre et rayon, arête de coupe super finition.
- Accutée d'arête de coupe parfaite.
- Performances excellentes à vitesse de coupe élevées.
- Carbure Submicrograin 0,2 µm.



0.05 ~ 2.5R

3R ~ 6R

List. p.61

d	Tolleranza/Tolérance
Ø 0.1 ~ 0.15	+0 ~ -0.005 mm
Ø 0.2 ~ 5	+0 ~ -0.01 mm
Ø 6 ~ 12	-0.005 ~ -0.015 mm

Unità: mm

Numero d'Ordine Reference	R x D	L1	L	d	Numero d'Ordine Reference	R x D	L1	L	d
2HSB 001 001 S04	0.05R X 0.1	0.1	40	4	2HSB 100 100 060	5R X 10	10	60	10
2HSB 001 0015 S04	0.05R X 0.1	0.15	40	4	2HSB 100 100 070	5R X 10	10	70	10
2HSB 0015 0015 S04	0.075R X 0.15	0.15	40	4	2HSB 120 120 060	6R X 12	12	60	12
2HSB 0015 002 S04	0.075R X 0.15	0.2	40	4	2HSB 120 120 070	6R X 12	12	70	12
2HSB 002 002 S04	0.1R X 0.2	0.2	40	4					
2HSB 002 003 S04	0.1R X 0.2	0.3	40	4					
2HSB 0025 004 S04	0.125R X 0.25	0.4	40	4					
2HSB 003 003 S04	0.15R X 0.3	0.3	40	4					
2HSB 003 0045 S04	0.15R X 0.3	0.45	40	4					
2HSB 004 004 S04	0.2R X 0.4	0.4	40	4					
2HSB 004 006 S04	0.2R X 0.4	0.6	40	4					
2HSB 005 005 S04	0.25R X 0.5	0.5	40	4					
2HSB 005 0075 S04	0.25R X 0.5	0.75	40	4					
2HSB 006 006 S04	0.3R X 0.6	0.6	40	4					
2HSB 006 009 S04	0.3R X 0.6	0.9	40	4					
2HSB 007 007 S04	0.35R X 0.7	0.7	40	4					
2HSB 007 010 S04	0.35R X 0.7	1	40	4					
2HSB 008 008 S04	0.4R X 0.8	0.8	40	4					
2HSB 008 012 S04	0.4R X 0.8	1.2	40	4					
2HSB 009 009 S04	0.45R X 0.9	0.9	40	4					
2HSB 009 013 S04	0.45R X 0.9	1.3	40	4					
2HSB 010 010 S04	0.5R X 1	1	40	4					
2HSB 010 010 S06	0.5R X 1	1	40	6					
2HSB 010 015 S04	0.5R X 1	1.5	40	4					
2HSB 010 015 S06	0.5R X 1	1.5	40	6					
2HSB 012 012 S04	0.6R X 1.2	1.2	40	4					
2HSB 015 015 S04	0.75R X 1.5	1.5	40	4					
2HSB 015 015 S06	0.75R X 1.5	1.5	40	6					
2HSB 015 023 S04	0.75R X 1.5	2.3	40	4					
2HSB 015 023 S06	0.75R X 1.5	2.3	40	6					
2HSB 020 020 S04	1R X 2	2	45	4					
2HSB 020 020 S06	1R X 2	2	45	6					
2HSB 020 030 S04	1R X 2	3	45	4					
2HSB 020 030 S06	1R X 2	3	45	6					
2HSB 025 025 S04	1.25R X 2.5	2.5	45	4					
2HSB 025 025 S06	1.25R X 2.5	2.5	45	6					
2HSB 030 030 S04	1.5R X 3	3	45	4					
2HSB 030 030 S06	1.5R X 3	3	45	6					
2HSB 030 045 S04	1.5R X 3	4.5	45	4					
2HSB 030 045 S06	1.5R X 3	4.5	45	6					
2HSB 040 040 S04	2R X 4	4	45	4					
2HSB 040 040 S06	2R X 4	4	45	6					
2HSB 040 060 S04	2R X 4	6	45	4					
2HSB 040 060 S06	2R X 4	6	45	6					
2HSB 050 050 S06	2.5R X 5	5	50	6					
2HSB 050 075 S06	2.5R X 5	7.5	50	6					
2HSB 060 060 050	3R X 6	6	50	6					
2HSB 060 060 060	3R X 6	6	60	6					
2HSB 080 080 050	4R X 8	8	50	8					
2HSB 080 080 060	4R X 8	8	60	8					

2HCB *Fraise Hémisphérique 2 Coupes Serie Standard*

Fresa Emisferica 2 Tagli Serie Standard

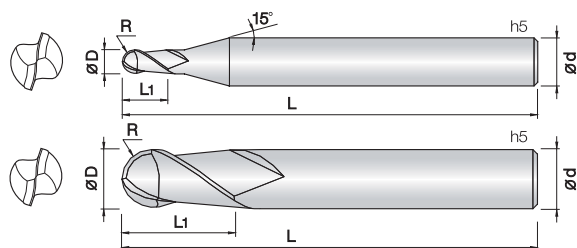

- **Fresa per acciai bonificati e temprati (HRc65)**
- Ottima resistenza all'usura grazie al nuovo rivestimento PVD a base Si.
- Elevata tolleranza del filo tagliente.
- Ottima finitura superficiale.
- Prestazioni eccellenti in alta velocità garantite dal metallo duro Ultra Micrograna (0,2 µm).
- **Fraise pour aciers alliés et trempés jusqu'à 62HRC de dureté.**
- Excellent contre l'usure rapide grâce au revêtement PVD à base de Si.
- Réduction des vibrations grâce à la longueur réduite de coupe.
- Tolérances élevées du diamètre et rayon, arête de coupe super finition.
- Accuîtée d'arête de coupe parfaite.
- Performances excellentes à vitesse de coupe élevées.
- Carbure Submicrograin 0,2 µm.

HARD series

UWC
초미립자

TISIN
Coating

R
±0.005

R
±0.01

R
±0.015

30
Helix Angle

€

0.03 ~ 2.93R 3 ~ 6R 6.5 ~ 10R List. p.62

d	Tolleranza/Tolérance
Ø 0.06 ~ 0.19	+0 ~ -0.005 mm
Ø 0.2 ~ 5.8	+0 ~ -0.01 mm
Ø 6 ~ 12	-0.005 ~ -0.015 mm
Ø 13 ~ 20	-0.01 ~ -0.02 mm

Unità: mm

Numero d'Ordine Reference	R x D	L1	L	d	Numero d'Ordine Reference	R x D	L1	L	d
2HCB 0006 001 S04	0.03R X 0.06	0.1	40	4	2HCB 030 080 100	1.5R X 3	8	100	
2HCB 0007 0012 S04	0.035R X 0.07	0.12	40	4	2HCB 032 080 S04	1.6R X 3.2	8	60	
2HCB 0008 0015 S04	0.04R X 0.08	0.15	40	4	2HCB 034 080 S04	1.7R X 3.4	8	60	
2HCB 0009 0017 S04	0.045R X 0.09	0.17	40	4	2HCB 035 080 S06	1.75R X 3.5	8	60	
2HCB 001 002 S04	0.05R X 0.1	0.2	40	4	2HCB 036 090 S04	1.8R X 3.6	9	60	
2HCB 0015 003 S04	0.075R X 0.15	0.3	40	4	2HCB 038 090 S04	1.9R X 3.8	9	60	
2HCB 002 004 S04	0.1R X 0.2	0.4	40	4	2HCB 040 080 060	2R X 4	8	60	
2HCB 003 006 S04	0.15R X 0.3	0.6	40	4	2HCB 040 080 080	2R X 4	8	80	
2HCB 004 008 S04	0.2R X 0.4	0.8	40	4	2HCB 040 080 S06	2R X 4	8	70	
2HCB 005 010 S04	0.25R X 0.5	1	45	4	2HCB 040 080 090	2R X 4	8	90	
2HCB 006 012 S04	0.3R X 0.6	1.2	45	4	2HCB 040 080 120	2R X 4	8	120	
2HCB 007 015 S04	0.35R X 0.7	1.5	45	4	2HCB 042 100 S06	2.1R X 4.2	10	70	
2HCB 008 020 S04	0.4R X 0.8	2	45	4	2HCB 044 100 S06	2.2R X 4.4	10	70	
2HCB 009 020 S04	0.45R X 0.9	2	45	4	2HCB 045 080 S06	2.25R X 4.5	8	70	
2HCB 010 025 S03	0.5R X 1	2.5	50	3	2HCB 046 100 S06	2.3R X 4.6	10	70	
2HCB 010 025 S04	0.5R X 1	2.5	50	4	2HCB 048 110 S06	2.4R X 4.8	11	70	
2HCB 010 025 S06	0.5R X 1	2.5	50	6	2HCB 050 080 S05	2.5R X 5	8	80	
2HCB 010 025 070	0.5R X 1	2.5	70	6	2HCB 050 100 S06	2.5R X 5	10	75	
2HCB 010 025 100	0.5R X 1	2.5	100	6	2HCB 052 120 S06	2.6R X 5.2	12	75	
2HCB 011 027 S04	0.55R X 1.1	2.7	50	4	2HCB 054 120 S06	2.7R X 5.4	12	75	
2HCB 012 030 S03	0.6R X 1.2	3	50	3	2HCB 055 100 S06	2.75R X 5.5	10	75	
2HCB 012 030 S04	0.6R X 1.2	3	50	4	2HCB 056 120 S06	2.8R X 5.6	12	75	
2HCB 013 032 S04	0.65R X 1.3	3.2	50	4	2HCB 058 120 S06	2.9R X 5.8	12	75	
2HCB 014 035 S04	0.7R X 1.4	3.5	50	4	2HCB 060 100 060	3R X 6	10	60	
2HCB 015 040 S03	0.75R X 1.5	4	50	3	2HCB 060 120 080	3R X 6	12	80	
2HCB 015 040 S04	0.75R X 1.5	4	50	4	2HCB 060 120 100	3R X 6	12	100	
2HCB 015 040 S06	0.75R X 1.5	4	50	6	2HCB 060 120 120	3R X 6	12	120	
2HCB 015 040 070	0.75R X 1.5	4	70	6	2HCB 060 120 150	3R X 6	12	150	
2HCB 015 040 100	0.75R X 1.5	4	100	6	2HCB 070 140 S08	3.5R X 7	14	80	
2HCB 016 040 S04	0.8R X 1.6	4	50	4	2HCB 080 140 090	4R X 8	14	90	
2HCB 017 042 S04	0.85R X 1.7	4.2	50	4	2HCB 080 140 110	4R X 8	14	110	
2HCB 018 045 S04	0.9R X 1.8	4.5	50	4	2HCB 080 140 150	4R X 8	14	150	
2HCB 019 047 S04	0.95R X 1.9	4.7	50	4	2HCB 090 160 S10	4.5R X 9	16	100	
2HCB 020 050 S03	1R X 2	5	50	3	2HCB 100 180 100	5R X 10	18	100	
2HCB 020 050 S04	1R X 2	5	50	4	2HCB 100 180 120	5R X 10	18	120	
2HCB 020 050 S06	1R X 2	5	50	6	2HCB 100 180 150	5R X 10	18	150	
2HCB 020 050 075	1R X 2	5	75	6	2HCB 100 180 180	5R X 10	18	180	
2HCB 020 050 100	1R X 2	5	100	6	2HCB 110 200 S12	5.5R X 11	20	110	
2HCB 022 055 S04	1.1R X 2.2	5.5	50	4	2HCB 120 220 110	6R X 12	22	110	
2HCB 024 060 S04	1.2R X 2.4	6	50	4	2HCB 120 220 130	6R X 12	22	130	
2HCB 025 060 S03	1.25R X 2.5	6	50	3	2HCB 120 220 150	6R X 12	22	150	
2HCB 025 060 S04	1.25R X 2.5	6	50	4	2HCB 120 220 200	6R X 12	22	200	
2HCB 025 060 S06	1.25R X 2.5	6	75	6	2HCB 130 240 S14	6.5R X 13	24	110	
2HCB 025 060 100	1.25R X 2.5	6	100	6	2HCB 140 240 S14	7R X 14	24	110	
2HCB 026 060 S04	1.3R X 2.6	6	50	4	2HCB 160 300 130	8R X 16	30	130	
2HCB 028 070 S04	1.4R X 2.8	7	50	4	2HCB 160 300 160	8R X 16	30	160	
2HCB 030 080 S03	1.5R X 3	8	60	3	2HCB 160 300 200	8R X 16	30	200	
2HCB 030 080 S04	1.5R X 3	8	50	4	2HCB 200 380 160	10R X 20	38	160	
2HCB 030 080 S06	1.5R X 3	8	60	6	2HCB 200 380 200	10R X 20	38	200	
2HCB 030 080 080	1.5R X 3	8	80	6					

3HCB Fraise Hémisphérique 3 Coupes Serie Standard

Fresa Emisferica 3 Tagli Serie Standard

HARD series

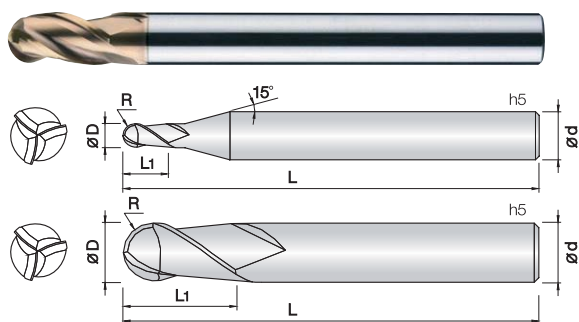

- **Fresa per acciai bonificati e temprati (HRc65)**
- Ottima resistenza all'usura grazie al nuovo rivestimento PVD a base Si.
- Elevata tolleranza del filo tagliente.
- Parametri di alta velocità e avanzamenti nell'utilizzo con il 4°asse.
- Prestazioni eccellenti in alta velocità garantite dal metallo duro Ultra Micrograna (0,2 µm).
- **Fraise pour aciers alliés et trempés jusqu'à 62HRc de dureté.**
- Excellent contre l'usure rapide grâce au revêtement PVD à base de Si.
- Tolérances élevées du diamètre et rayon, arête de coupe super finition.
- Accutée d'arête de coupe parfaite.
- Performances excellentes à vitesse de coupe élevées.
- Carbure Submicrograin 0,2 µm.



0.5 ~ 2.5R

3R ~ 6R

List. p.63

d	Tolleranza/Tolérance
Ø 2 ~ 5	+0 ~ -0.01 mm
Ø 6 ~ 12	-0.005 ~ -0.015 mm

Unità: mm

Numero d'Ordine Reference	R x D	L1	L	d	Numero d'Ordine Reference	R x D	L1	L	d
3HCB 010 250 S04	0.5R X 1	2.5	50	4	New 3HCB 060 120 120	3R X 6	12	120	6
3HCB 015 040 S04	0.75R X 1.5	4	50	4	3HCB 080 140 S08	4R X 8	14	90	8
3HCB 020 050 S06	1R X 2	5	50	6	New 3HCB 080 140 150	4R X 8	14	150	8
3HCB 030 080 S06	1.5R X 3	8	65	6	3HCB 100 180 S10	5R X 10	18	100	10
3HCB 040 080 S04	2R X 4	8	60	4	New 3HCB 100 180 150	5R X 10	18	150	10
3HCB 040 080 S06	2R X 4	8	70	6	3HCB 120 220 S12	6R X 12	22	110	12
3HCB 050 100 S06	2.5R X 5	10	75	6	New 3HCB 120 220 150	6R X 12	22	150	12
3HCB 060 120 S06	3R X 6	12	80	6					

4HSB Fraise Hémisphérique 4 Coupes Serie Courte

Fresa Emisferica 4 Tagli Serie Corta

New

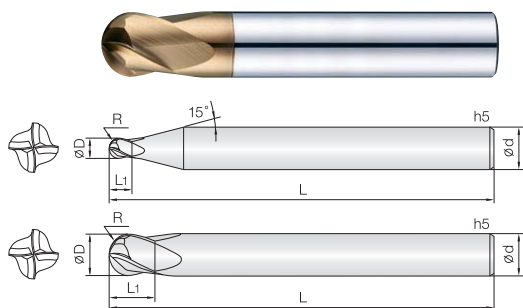

- **Fresa per acciai bonificati e temprati (HRc65)**
- Ottima resistenza all'usura grazie al nuovo rivestimento PVD a base Si.
- Elevata tolleranza del filo tagliente.
- Serie corta per un facile uso su mandrini a calettare.
- Parametri di alta velocità e avanzamenti grazie ai 4 taglienti.
- Prestazioni eccellenti in alta velocità garantite dal metallo duro Ultra Micrograna (0,2 µm).
- **Fraise pour aciers alliés et trempés jusqu'à 62HRc de dureté.**
- Excellent contre l'usure rapide grâce au revêtement PVD à base de Si.
- Tolérances élevées du diamètre et rayon, arête de coupe super finition.
- Paramètres en haute vitesse et avance grâce aux 4 coupes.
- Performances excellentes à vitesse de coupe élevées.
- Carbure Submicrograin 0,2 µm.



0.5 ~ 2.5R

3R ~ 6R

List. p.63

d	Tolleranza/Tolérance
Ø 1 ~ 5	+0 ~ -0.01 mm
Ø 6 ~ 12	-0.005 ~ -0.015 mm

Unità: mm

Numero d'Ordine Reference	R x D	L1	L	d	Numero d'Ordine Reference	R x D	L1	L	d
4HSB 010 012 S04	0.5R X 1	1.2	40	4					
4HSB 012 015 S04	0.6R X 1.2	1.5	40	4					
4HSB 015 018 S04	0.75R X 1.5	1.8	40	4					
4HSB 020 024 S04	1R X 2	2.4	40	4					
4HSB 025 030 S04	1.25R X 2.5	3	45	4					
4HSB 030 036 S06	1.5R X 3	3.6	45	6					
4HSB 040 050 S04	2R X 4	5	45	4					
4HSB 040 050 S06	2R X 4	5	45	6					
4HSB 050 060 S06	2.5R X 5	6	50	6					
4HSB 060 070 S06	3R X 6	7	50	6					
4HSB 060 070 060	3R X 6	7	60	6					
4HSB 080 080 S08	4R X 8	8	60	8					
4HSB 100 100 S10	5R X 10	10	60	10					
4HSB 120 120 S12	6R X 12	12	75	12					

2HRE *Fraise Cylindrique 2 Coupes pour Rainurage* *Fresa Cilindrica 2 Tagli per Nervature*

HARD series

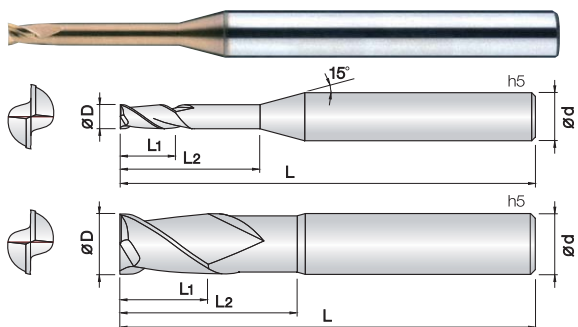

- **Fresa per acciai bonificati e temprati (HRc65)**
- Ottima resistenza all'usura grazie al nuovo rivestimento PVD a base Si.
- Elevata tolleranza del filo tagliente.
- Geometria rinforzata per prevenire scheggiature del tagliente.
- Prestazioni eccellenti in alta velocità garantite dal metallo duro Ultra Micrograna (0,2 µm).
- **Fraise pour aciers alliés et trempés jusqu'à (HRc65) de dureté.**
- Excellent contre l'usure rapide grâce au revêtement PVD à base de Si
- Tolérances élevée du diamètre et rayon, arête de coupe super finition.
- Géométrie renforcée pour prévenir de l'usure de l'arête de coupe.
- Performances excellentes à vitesse de coupe élevées.
- Carbure Submicrograin 0,2 µm.



d	Tolleranza/Tolérance
Ø 0.1	+0 ~ -0.005 mm
Ø 0.2 ~ 5	+0 ~ -0.01 mm
Ø 6 ~ 12	-0.01 ~ -0.025 mm

Unità: mm

Numero d'Ordine Reference	D	L1	L2	L	d	Numero d'Ordine Reference	D	L1	L2	L	d
2HRE 001 003 S04	0.1	0.15	0.3	40	4	2HRE 006 050 S04	0.6	0.6	5	40	
2HRE 001 005 S04	0.1	0.15	0.5	40	4	2HRE 006 060 S04	0.6	0.6	6	40	
2HRE 0015 003 S04	0.15	0.15	0.3	40	4	2HRE 006 080 S04	0.6	0.6	8	40	
2HRE 0015 005 S04	0.15	0.15	0.5	40	4	2HRE 006 100 S04	0.6	0.6	10	40	
2HRE 0015 0075 S04	0.15	0.15	0.75	40	4	2HRE 006 120 S04	0.6	0.6	12	45	
2HRE 0015 010 S04	0.15	0.15	1	40	4	2HRE 006 140 S04	0.6	0.6	14	45	
2HRE 002 005 S04	0.2	0.2	0.5	40	4	2HRE 006 160 S04	0.6	0.6	16	45	
2HRE 002 010 S04	0.2	0.2	1	40	4	2HRE 007 020 S04	0.7	0.7	2	40	
2HRE 002 015 S04	0.2	0.2	1.5	40	4	2HRE 007 040 S04	0.7	0.7	4	40	
2HRE 002 020 S04	0.2	0.2	2	40	4	2HRE 007 060 S04	0.7	0.7	6	40	
2HRE 002 025 S04	0.2	0.2	2.5	40	4	2HRE 007 080 S04	0.7	0.7	8	40	
2HRE 002 030 S04	0.2	0.2	3	40	4	2HRE 007 100 S04	0.7	0.7	10	40	
2HRE 0025 005 S04	0.25	0.25	0.5	40	4	2HRE 007 120 S04	0.7	0.7	12	45	
2HRE 0025 010 S04	0.25	0.25	1	40	4	2HRE 008 020 S04	0.8	0.8	2	40	
2HRE 0025 015 S04	0.25	0.25	1.5	40	4	2HRE 008 030 S04	0.8	0.8	3	40	
2HRE 0025 020 S04	0.25	0.25	2	40	4	2HRE 008 040 S04	0.8	0.8	4	40	
2HRE 0025 030 S04	0.25	0.25	3	40	4	2HRE 008 050 S04	0.8	0.8	5	40	
2HRE 003 010 S04	0.3	0.3	1	40	4	2HRE 008 060 S04	0.8	0.8	6	40	
2HRE 003 015 S04	0.3	0.3	1.5	40	4	2HRE 008 080 S04	0.8	0.8	8	40	
2HRE 003 020 S04	0.3	0.3	2	40	4	2HRE 008100 S04	0.8	0.8	10	40	
2HRE 003 025 S04	0.3	0.3	2.5	40	4	2HRE 008120 S04	0.8	0.8	12	45	
2HRE 003 030 S04	0.3	0.3	3	40	4	2HRE 008140 S04	0.8	0.8	14	45	
2HRE 003 035 S04	0.3	0.3	3.5	40	4	2HRE 009 060 S04	0.9	0.9	6	40	
2HRE 003 040 S04	0.3	0.3	4	40	4	2HRE 009 080 S04	0.9	0.9	8	40	
2HRE 003 050 S04	0.3	0.3	5	40	4	2HRE 009 100 S04	0.9	0.9	10	40	
2HRE 004 010 S04	0.4	0.4	1	40	4	2HRE 010 020 S04	1	1	2	45	
2HRE 004 015 S04	0.4	0.4	1.5	40	4	2HRE 010 030 S04	1	1	3	45	
2HRE 004 020 S04	0.4	0.4	2	40	4	2HRE 010 040 S04	1	1	4	45	
2HRE 004 025 S04	0.4	0.4	2.5	40	4	2HRE 010 050 S04	1	1	5	45	
2HRE 004 030 S04	0.4	0.4	3	40	4	2HRE 010 060 S04	1	1	6	45	
2HRE 004 035 S04	0.4	0.4	3.5	40	4	2HRE 010 080 S04	1	1	8	45	
2HRE 004 040 S04	0.4	0.4	4	40	4	2HRE 010 100 S04	1	1	10	45	
2HRE 004 050 S04	0.4	0.4	5	40	4	2HRE 010 120 S04	1	1	12	45	
2HRE 004 060 S04	0.4	0.4	6	40	4	2HRE 010 140 S04	1	1	14	45	
2HRE 004 080 S04	0.4	0.4	8	40	4	2HRE 010 160 S04	1	1	16	50	
2HRE 004 100 S04	0.4	0.4	10	40	4	2HRE 010 180 S04	1	1	18	50	
2HRE 005 010 S04	0.5	0.5	1	40	4	2HRE 010 200 S04	1	1	20	50	
2HRE 005 020 S04	0.5	0.5	2	40	4	2HRE 010 250 S04	1	1	25	60	
2HRE 005 030 S04	0.5	0.5	3	40	4	2HRE 010 300 S04	1	1	30	70	
2HRE 005 040 S04	0.5	0.5	4	40	4	2HRE 012 040 S04	1.2	1.2	4	45	
2HRE 005 050 S04	0.5	0.5	5	40	4	2HRE 012 060 S04	1.2	1.2	6	45	
2HRE 005 060 S04	0.5	0.5	6	40	4	2HRE 012 080 S04	1.2	1.2	8	45	
2HRE 005 080 S04	0.5	0.5	8	40	4	2HRE 012 100 S04	1.2	1.2	10	45	
2HRE 005 100 S04	0.5	0.5	10	40	4	2HRE 012 120 S04	1.2	1.2	12	45	
2HRE 005 120 S04	0.5	0.5	12	45	4	2HRE 012 160 S04	1.2	1.2	16	50	
2HRE 005 140 S04	0.5	0.5	14	45	4	2HRE 012 200 S04	1.2	1.2	20	50	
2HRE 006 010 S04	0.6	0.6	1	40	4	2HRE 012 250 S04	1.2	1.2	25	60	
2HRE 006 020 S04	0.6	0.6	2	40	4	2HRE 012 300 S04	1.2	1.2	30	70	
2HRE 006 030 S04	0.6	0.6	3	40	4	2HRE 014 060 S04	1.4	1.4	6	45	
2HRE 006 040 S04	0.6	0.6	4	40	4	2HRE 014 080 S04	1.4	1.4	8	45	

Unità: mm

Numero d'Ordine Reference	D	L1	L2	L	d	Numero d'Ordine Reference	D	L1	L2	L	d
2HRE 014 100 S04	1.4	1.4	10	45	4	2HRE 030 120 S06	3	3	12	50	6
2HRE 014 140 S04	1.4	1.4	14	45	4	2HRE 030 160 S06	3	3	16	55	6
2HRE 014 160 S04	1.4	1.4	16	50	4	2HRE 030 200 S06	3	3	20	60	6
2HRE 014 200 S04	1.4	1.4	20	50	4	2HRE 030 250 S06	3	3	25	65	6
2HRE 015 040 S04	1.5	1.5	4	45	4	2HRE 030 300 S06	3	3	30	70	6
2HRE 015 060 S04	1.5	1.5	6	45	4	2HRE 030 350 S06	3	3	35	75	6
2HRE 015 080 S04	1.5	1.5	8	45	4	2HRE 030 400 S06	3	3	40	80	6
2HRE 015 100 S04	1.5	1.5	10	45	4	2HRE 030 450 S06	3	3	45	90	6
2HRE 015 120 S04	1.5	1.5	12	45	4	2HRE 030 500 S06	3	3	50	100	6
2HRE 015 140 S04	1.5	1.5	14	50	4	2HRE 030 600 S06	3	3	60	100	6
2HRE 015 160 S04	1.5	1.5	16	50	4	2HRE 040 080 S06	4	4	8	50	6
2HRE 015 180 S04	1.5	1.5	18	50	4	2HRE 040 100 S06	4	4	10	50	6
2HRE 015 200 S04	1.5	1.5	20	50	4	2HRE 040 120 S06	4	4	12	50	6
2HRE 015 250 S04	1.5	1.5	25	60	4	2HRE 040 160 S06	4	4	16	55	6
2HRE 015 300 S04	1.5	1.5	30	70	4	2HRE 040 200 S06	4	4	20	60	6
2HRE 016 100 S04	1.6	1.6	10	45	4	2HRE 040 250 S06	4	4	25	65	6
2HRE 016 140 S04	1.6	1.6	14	45	4	2HRE 040 300 S06	4	4	30	70	6
2HRE 016 180 S04	1.6	1.6	18	50	4	2HRE 040 350 S06	4	4	35	75	6
2HRE 018 100 S04	1.8	1.8	10	45	4	2HRE 040 400 S06	4	4	40	80	6
2HRE 018 140 S04	1.8	1.8	14	45	4	2HRE 040 450 S06	4	4	45	90	6
2HRE 018 180 S04	1.8	1.8	18	50	4	2HRE 040 500 S06	4	4	50	100	6
2HRE 020 040 S04	2	2	4	45	4	2HRE 040 550 S06	4	4	55	100	6
2HRE 020 060 S04	2	2	6	45	4	2HRE 040 600 S06	4	4	60	100	6
2HRE 020 080 S04	2	2	8	45	4	2HRE 050 160 S06	5	6	16	55	6
2HRE 020 100 S04	2	2	10	45	4	2HRE 050 200 S06	5	6	20	60	6
2HRE 020 120 S04	2	2	12	45	4	2HRE 050 250 S06	5	6	25	65	6
2HRE 020 140 S04	2	2	14	45	4	2HRE 050 300 S06	5	6	30	70	6
2HRE 020 160 S04	2	2	16	50	4	2HRE 050 350 S06	5	6	35	75	6
2HRE 020 180 S04	2	2	18	50	4	2HRE 050 400 S06	5	6	40	80	6
2HRE 020 200 S04	2	2	20	50	4	2HRE 050 500 S06	5	6	50	100	6
2HRE 020 220 S04	2	2	22	60	4	2HRE 050 600 S06	5	6	60	100	6
2HRE 020 250 S04	2	2	25	60	4	2HRE 060 200 S06	6	10	20	60	6
2HRE 020 300 S04	2	2	30	60	4	2HRE 060 300 S06	6	10	30	75	6
2HRE 020 350 S04	2	2	35	70	4	2HRE 060 400 S06	6	10	40	80	6
2HRE 020 400 S04	2	2	40	80	4	2HRE 060 500 S06	6	10	50	90	6
2HRE 020 450 S04	2	2	45	80	4	2HRE 060 600 S06	6	10	60	110	6
2HRE 020 500 S04	2	2	50	90	4	2HRE 080 200 S08	8	12	20	65	8
2HRE 025 080 S04	2.5	2.5	8	45	4	2HRE 080 300 S08	8	12	30	80	8
2HRE 025 100 S04	2.5	2.5	10	45	4	2HRE 080 400 S08	8	12	40	100	8
2HRE 025 120 S04	2.5	2.5	12	45	4	2HRE 100 250 S10	10	15	25	70	10
2HRE 025 160 S04	2.5	2.5	16	50	4	2HRE 100 350 S10	10	15	35	80	10
2HRE 025 200 S04	2.5	2.5	20	50	4	2HRE 100 450 S10	10	15	45	100	10
2HRE 025 250 S04	2.5	2.5	25	60	4	2HRE 120 300 S12	12	18	30	80	12
2HRE 025 300 S04	2.5	2.5	30	70	4	2HRE 120 400 S12	12	18	40	100	12
2HRE 025 350 S04	2.5	2.5	35	70	4	2HRE 120 500 S12	12	18	50	120	12
2HRE 025 400 S04	2.5	2.5	40	80	4						
2HRE 025 500 S04	2.5	2.5	50	90	4						
2HRE 030 060 S06	3	3	6	45	6						
2HRE 030 080 S06	3	3	8	45	6						
2HRE 030 100 S06	3	3	10	45	6						

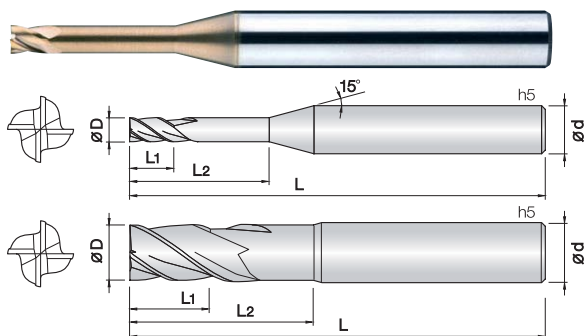

- **Fresa per acciai bonificati e temprati (HRC65)**
- Ottima resistenza all'usura grazie al nuovo rivestimento PVD a base SI.
- Elevata tolleranza del filo tagliente.
- Geometria rinforzata per prevenire scheggiature del tagliente.
- Prestazioni eccellenti in alta velocità garantite dal metallo duro Ultra Micrograna (0,2 µm).
- **Fraise pour aciers alliés et trempés jusqu'à (HRC65) de dureté.**
- Excellent contre l'usure rapide grâce au revêtement PVD à base de Si
- Tolérances élevées du diamètre et rayon, arête de coupe super finition.
- Géométrie renforcée pour prévenir de l'usure de l'arête de coupe.
- Performances excellentes à vitesse de coupe élevées.
- Carbure Submicrograin 0,2 µm.



d	Tolleranza/Tolérance
ø0.8 ~ 5	+0 ~ -0.01 mm
ø6 ~ 12	-0.01 ~ -0.025 mm

Unità: mm

Numero d'Ordine Reference	D	L1	L2	L	d	Numero d'Ordine Reference	D	L1	L2	L	d
4HRE 005 010 S04	0.5	0.5	1	45	4	4HRE 015 060 S04	1.5	1.5	6		
4HRE 005 020 S04	0.5	0.5	2	45	4	4HRE 015 080 S04	1.5	1.5	8		
4HRE 005 030 S04	0.5	0.5	3	45	4	4HRE 015 100 S04	1.5	1.5	10		
4HRE 005 040 S04	0.5	0.5	4	45	4	4HRE 015 120 S04	1.5	1.5	12		
4HRE 005 050 S04	0.5	0.5	5	45	4	4HRE 015 160 S04	1.5	1.5	16		
4HRE 005 060 S04	0.5	0.5	6	45	4	4HRE 015 200 S04	1.5	1.5	20		
4HRE 005 080 S04	0.5	0.5	8	45	4	4HRE 015 250 S04	1.5	1.5	25		
4HRE 005 100 S04	0.5	0.5	10	50	4	4HRE 020 040 S04	2	2	4		
4HRE 006 010 S04	0.6	0.6	1	45	4	4HRE 020 060 S04	2	2	6		
4HRE 006 020 S04	0.6	0.6	2	45	4	4HRE 020 080 S04	2	2	8		
4HRE 006 030 S04	0.6	0.6	3	45	4	4HRE 020 100 S04	2	2	10		
4HRE 006 040 S04	0.6	0.6	4	45	4	4HRE 020 120 S04	2	2	12		
4HRE 006 060 S04	0.6	0.6	6	45	4	4HRE 020 140 S04	2	2	14		
4HRE 006 080 S04	0.6	0.6	8	45	4	4HRE 020 160 S04	2	2	16		
4HRE 006 100 S04	0.6	0.6	10	50	4	4HRE 020 180 S04	2	2	18		
4HRE 006 120 S04	0.6	0.6	12	50	4	4HRE 020 200 S04	2	2	20		
4HRE 007 020 S04	0.7	0.7	2	45	4	4HRE 020 250 S04	2	2	25		
4HRE 007 040 S04	0.7	0.7	4	45	4	4HRE 020 300 S04	2	2	30		
4HRE 007 060 S04	0.7	0.7	6	45	4	4HRE 025 100 S04	2.5	2.5	10		
4HRE 007 080 S04	0.7	0.7	8	45	4	4HRE 025 120 S04	2.5	2.5	12		
4HRE 007 100 S04	0.7	0.7	10	50	4	4HRE 025 160 S04	2.5	2.5	16		
4HRE 008 020 S04	0.8	0.8	2	45	4	4HRE 025 200 S04	2.5	2.5	20		
4HRE 008 040 S04	0.8	0.8	4	45	4	4HRE 025 250 S04	2.5	2.5	25		
4HRE 008 060 S04	0.8	0.8	6	45	4	4HRE 025 300 S04	2.5	2.5	30		
4HRE 008 080 S04	0.8	0.8	8	45	4	4HRE 030 060 S06	3	3	6		
4HRE 008 100 S04	0.8	0.8	10	45	4	4HRE 030 080 S06	3	3	8		
4HRE 008 120 S04	0.8	0.8	12	45	4	4HRE 030 100 S06	3	3	10		
4HRE 008 160 S04	0.8	0.8	16	50	4	4HRE 030 120 S06	3	3	12		
4HRE 009 020 S04	0.9	0.9	2	45	4	4HRE 030 160 S06	3	3	16		
4HRE 009 060 S04	0.9	0.9	6	45	4	4HRE 030 200 S06	3	3	20		
4HRE 009 080 S04	0.9	0.9	8	45	4	4HRE 030 250 S06	3	3	25		
4HRE 009 100 S04	0.9	0.9	10	45	4	4HRE 030 300 S06	3	3	30		
4HRE 010 020 S04	1	1	2	45	4	4HRE 030 350 S06	3	3	35		
4HRE 010 030 S04	1	1	3	45	4	4HRE 030 400 S06	3	3	40		
4HRE 010 040 S04	1	1	4	45	4	New 4HRE 030 450 S06	3	3	45		
4HRE 010 060 S04	1	1	6	45	4	New 4HRE 030 500 S06	3	3	50		
4HRE 010 080 S04	1	1	8	45	4	New 4HRE 035 120 S06	3.5	3.5	12		
4HRE 010 100 S04	1	1	10	45	4	New 4HRE 035 160 S06	3.5	3.5	16		
4HRE 010 120 S04	1	1	12	45	4	New 4HRE 035 200 S06	3.5	3.5	20		
4HRE 010 140 S04	1	1	14	50	4	New 4HRE 035 250 S06	3.5	3.5	25		
4HRE 010 160 S04	1	1	16	50	4	New 4HRE 035 300 S06	3.5	3.5	30		
4HRE 010 200 S04	1	1	20	50	4	4HRE 040 060 S06	4	4	6		
4HRE 010 250 S04	1	1	25	60	4	4HRE 040 080 S06	4	4	8		
4HRE 012 040 S04	1.2	1.2	4	45	4	4HRE 040 100 S06	4	4	10		
4HRE 012 060 S04	1.2	1.2	6	45	4	4HRE 040 120 S06	4	4	12		
4HRE 012 080 S04	1.2	1.2	8	45	4	4HRE 040 160 S06	4	4	16		
4HRE 012 100 S04	1.2	1.2	10	45	4	4HRE 040 200 S06	4	4	20		
4HRE 012 120 S04	1.2	1.2	12	45	4	4HRE 040 250 S06	4	4	25		
4HRE 012 160 S04	1.2	1.2	16	50	4	4HRE 040 300 S06	4	4	30		
4HRE 015 040 S04	1.5	1.5	4	45	4	4HRE 040 400 S06	4	4	40		

2HCE *Fraise Cylindrique 2 Coupes Serie Standard*

Fresa Cilindrica 2 Tagli Serie Standard

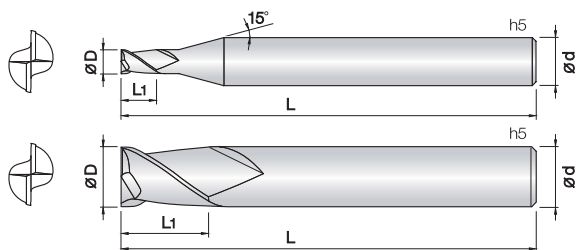

- **Fresa per acciai bonificati e temprati (HRC65)**
- Ottima resistenza all'usura grazie al nuovo rivestimento PVD a base Si.
- Elevata tolleranza del filo tagliente.
- Geometria rinforzata per prevenire scheggiature del tagliente.
- Produzione a partire da diametro 0,05 mm.
- Prestazioni eccellenti in alta velocità garantite dal metallo duro Ultra Micrograna (0,2 µm).
- **Fraise pour aciers alliés et trempés jusqu'à (HRC65) de dureté.**
- Excellent contre l'usure rapide grâce au revêtement PVD à base de Si
- Tolérances élevée du diamètre et rayon, arête de coupe super finition.
- Géométrie renforcée pour prévenir de l'usure de l'arête de coupe.
- Production a partir de diamètre 0,05 mm.
- Performances excellentes à vitesse de coupe élevées.
- Carbure Submicrograin 0,2 µm.

HARD series

2

WC
미립자

TISIN
Coating

D
+0 -0.005

D
+0 -0.01

D
-0.01 -0.025

D
-0.015 -0.03

30°
Helix Angle

Rinforzato

€

Ø0.05 ~ 0.15
Ø0.2 ~ 5.9
Ø6 ~ 12
Ø13 ~ 20
List. p.69

d	Tolleranza/Tolérance
Ø 0.05 ~ 0.15	+0 ~ -0.005 mm
Ø 0.2 ~ 5.9	+0 ~ -0.01 mm
Ø 6 ~ 12	-0.01 ~ -0.025 mm
Ø 13 ~ 20	-0.015 ~ -0.03 mm

Unità: mm

Numero d'Ordine <i>Reference</i>	D	L1	L	d	Numero d'Ordine <i>Reference</i>	D	L1	L	d
2HCE 0005 0008 S04	0.05	0.08	40	4	2HCE 018 045 S04	1.8	4.5	40	4
New 2HCE 0006 001 S04	0.06	0.1	40	4	2HCE 0185 045 S04	1.85	4.5	40	4
2HCE 0007 0012 S04	0.07	0.12	40	4	2HCE 019 050 S04	1.9	5	40	4
New 2HCE 0008 0015 S04	0.08	0.15	40	4	2HCE 0195 050 S04	1.95	5	40	4
2HCE 0009 0017 S04	0.09	0.17	40	4	2HCE 020 060 S03	2	6	40	3
2HCE 001 002 S04	0.1	0.2	40	4	2HCE 020 060 S04	2	6	40	4
2HCE 0015 003 S04	0.15	0.3	40	4	2HCE 020 060 S06	2	6	40	6
2HCE 002 004 S04	0.2	0.4	40	4	2HCE 020 060 060	2	6	60	6
2HCE 0025 005 S04	0.25	0.5	40	4	2HCE 021 060 S04	2.1	6	40	4
2HCE 003 006 S04	0.3	0.6	40	4	2HCE 022 060 S04	2.2	6	40	4
2HCE 0035 007 S04	0.35	0.7	40	4	2HCE 023 060 S04	2.3	6	40	4
2HCE 004 008 S04	0.4	0.8	40	4	2HCE 024 080 S04	2.4	8	45	4
2HCE 0045 009 S04	0.45	0.9	40	4	2HCE 025 080 S03	2.5	8	45	3
2HCE 005 010 S03	0.5	1	40	3	2HCE 025 080 S04	2.5	8	45	4
2HCE 005 010 S04	0.5	1	40	4	2HCE 025 080 S06	2.5	8	45	6
2HCE 0055 011 S04	0.55	1.1	40	4	2HCE 025 080 070	2.5	8	70	6
2HCE 006 012 S03	0.6	1.2	40	3	2HCE 026 080 S04	2.6	8	45	4
2HCE 006 012 S04	0.6	1.2	40	4	2HCE 027 080 S04	2.7	8	45	4
2HCE 0065 013 S04	0.65	1.3	40	4	2HCE 028 080 S04	2.8	8	45	4
2HCE 007 014 S04	0.7	1.4	40	4	2HCE 029 080 S04	2.9	8	45	4
2HCE 0075 015 S04	0.75	1.5	40	4	2HCE 030 080 S03	3	8	45	3
2HCE 008 016 S03	0.8	1.6	40	3	2HCE 030 080 S04	3	8	45	4
2HCE 008 016 S04	0.8	1.6	40	4	2HCE 030 080 S06	3	8	45	6
2HCE 0085 017 S04	0.85	1.7	40	4	2HCE 030 080 070	3	8	70	6
2HCE 009 020 S04	0.9	2	40	4	2HCE 031 080 S06	3.1	8	45	6
2HCE 0095 020 S04	0.95	2	40	4	2HCE 032 080 S06	3.2	8	45	6
2HCE 010 025 S03	1	2.5	40	3	2HCE 033 080 S06	3.3	8	45	6
2HCE 010 025 S04	1	2.5	40	4	2HCE 034 080 S06	3.4	8	45	6
2HCE 010 025 S06	1	2.5	40	6	2HCE 035 100 S06	3.5	10	45	6
2HCE 010 025 060	1	2.5	60	6	2HCE 036 100 S06	3.6	10	45	6
2HCE 0105 025 S04	1.05	2.5	40	4	2HCE 037 100 S06	3.7	10	45	6
2HCE 011 027 S04	1.1	2.7	40	4	2HCE 038 100 S06	3.8	10	45	6
2HCE 0115 025 S04	1.15	2.5	40	4	2HCE 039 100 S06	3.9	10	45	6
2HCE 012 030 S03	1.2	3	40	3	2HCE 040 100 S04	4	10	45	4
2HCE 012 030 S04	1.2	3	40	4	2HCE 040 110 S06	4	11	45	6
2HCE 012 030 060	1.2	3	60	6	2HCE 040 110 070	4	11	70	6
2HCE 0125 030 S04	1.25	3	40	4	2HCE 041 110 S06	4.1	11	45	6
2HCE 013 032 S04	1.3	3.2	40	4	2HCE 042 110 S06	4.2	11	45	6
2HCE 0135 032 S04	1.35	3.2	40	4	2HCE 043 110 S06	4.3	11	45	6
2HCE 014 035 S04	1.4	3.5	40	4	2HCE 044 110 S06	4.4	11	45	6
2HCE 0145 035 S04	1.45	3.5	40	4	2HCE 045 110 S06	4.5	11	45	6
2HCE 015 040 S03	1.5	4	40	3	2HCE 046 110 S06	4.6	11	45	6
2HCE 015 040 S04	1.5	4	40	4	2HCE 047 110 S06	4.7	11	45	6
2HCE 015 040 S06	1.5	4	40	6	2HCE 048 110 S06	4.8	11	45	6
2HCE 015 040 060	1.5	4	60	6	2HCE 049 110 S06	4.9	11	45	6
2HCE 0155 040 S04	1.55	4	40	4	2HCE 050 130 S06	5	13	50	6
2HCE 016 040 S04	1.6	4	40	4	2HCE 050 130 080	5	13	80	6
2HCE 0165 040 S04	1.65	4	40	4	2HCE 051 130 S06	5.1	13	50	6
2HCE 017 042 S04	1.7	4.2	40	4	2HCE 052 130 S06	5.2	13	50	6
2HCE 0175 042 S04	1.75	4.2	40	4	2HCE 053 130 S06	5.3	13	50	6

2LEM *Fraise Cylindrique 2 Coupes Serie Lounge* *Fresa Cilindrica 2 Tagli Serie Lunga*

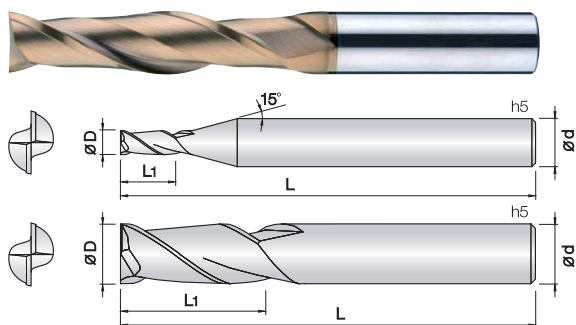

- Fresa per differenti applicazioni su vari materiali, ghisa, acciai legati, acciai bonificati e temprati fino a HRc55
- Ottima resistenza all'usura grazie al nuovo rivestimento PVD a base SI.
- Vibrazioni ridotte grazie a run-out e tolleranze precise.
- Ampia gamma di lunghezze per le più svariate applicazioni.
- Geometria rinforzata per prevenire scheggiature del tagliente.
- *Fraise pour applications sur différentes matières, fonte, aciers alliés et fortement alliés et trempés jusqu'à 55HRc.*
- *Excellent contre l'usure rapide grâce au revêtement PVD à base de Si.*
- *Réduction de vibration et Tolérance précise.*
- *Gamme de longueurs importante pour plus de variante d'usinage.*
- *Geométrie renforcée pour prévenir de l'usure de l'arête de coupe.*

HARD series

2

WC
마립자

TISIN
Coating

D
+0 -0.01

D
-0.01 -0.025

D
-0.015 -0.03

30°
Helix Angle

Rinforzato

€

d	Tolleranza/Tolérance
Ø 1 ~ 5	+0 ~ -0.01 mm
Ø 6 ~ 12	-0.01 ~ -0.025 mm
Ø 14 ~ 25	-0.015 ~ -0.03 mm

Unità: mm

Numero d'Ordine Reference	D	L1	L	d	Numero d'Ordine Reference	D	L1	L	d
2LEM 010 030 S06	1	3	60	6	2LEM 080 250 S08	8	25	75	8
2LEM 010 050 S06	1	5	60	6	2LEM 080 250 100	8	25	100	8
2LEM 010 070 S06	1	7	60	6	2LEM 080 300 S08	8	30	80	8
2LEM 010 100 S06	1	10	60	6	2LEM 080 350 S08	8	35	80	8
2LEM 010 120 S06	1	12	60	6	2LEM 080 400 S08	8	40	90	8
2LEM 010 150 S06	1	15	60	6	2LEM 080 450 S08	8	45	100	8
New 2LEM 012 060 S06	1.2	6	60	6	2LEM 080 500 S08	8	50	100	8
New 2LEM 012 080 S06	1.2	8	60	6	2LEM 080 550 S08	8	55	100	8
New 2LEM 012 100 S06	1.2	10	60	6	2LEM 080 600 S08	8	60	110	8
New 2LEM 012 120 S06	1.2	12	60	6	2LEM 100 300 S10	10	30	80	10
2LEM 015 060 S06	1.5	6	60	6	2LEM 100 300 110	10	30	110	10
2LEM 015 075 S06	1.5	7.5	60	6	2LEM 100 350 S10	10	35	90	10
2LEM 015 100 S06	1.5	10	60	6	2LEM 100 400 S10	10	40	90	10
2LEM 015 150 S06	1.5	15	60	6	2LEM 100 450 S10	10	45	100	10
2LEM 015 200 S06	1.5	20	60	6	2LEM 100 500 S10	10	50	100	10
2LEM 020 060 S06	2	6	60	6	2LEM 100 550 S10	10	55	110	10
2LEM 020 100 S06	2	10	60	6	2LEM 100 600 S10	10	60	110	10
2LEM 020 150 S06	2	15	60	6	2LEM 100 650 S10	10	65	120	10
2LEM 020 200 S06	2	20	60	6	2LEM 100 700 S10	10	70	120	10
New 2LEM 025 100 S06	2.5	10	60	6	2LEM 120 300 S12	12	30	90	12
New 2LEM 025 150 S06	2.5	15	60	6	2LEM 120 350 S12	12	35	110	12
New 2LEM 025 200 S06	2.5	20	60	6	2LEM 120 400 S12	12	40	100	12
2LEM 030 120 S06	3	12	70	6	2LEM 120 450 S12	12	45	100	12
2LEM 030 150 S06	3	15	70	6	2LEM 120 500 S12	12	50	100	12
2LEM 030 200 S06	3	20	70	6	2LEM 120 550 S12	12	55	110	12
2LEM 030 250 S06	3	25	70	6	2LEM 120 600 S12	12	60	110	12
2LEM 030 300 S06	3	30	70	6	2LEM 120 700 S12	12	70	130	12
New 2LEM 035 120 S06	3.5	12	70	6	2LEM 120 800 S12	12	80	130	12
New 2LEM 035 150 S06	3.5	15	70	6	2LEM 140 500 S14	14	50	110	14
New 2LEM 035 200 S06	3.5	20	70	6	2LEM 160 400 160	16	40	160	16
2LEM 040 150 S06	4	15	70	6	2LEM 160 550 S16	16	55	120	16
2LEM 040 200 S06	4	20	70	6	2LEM 160 700 S16	16	70	130	16
2LEM 040 300 S06	4	30	75	6	2LEM 160 800 S16	16	80	160	16
2LEM 040 350 S06	4	35	75	6	2LEM 160 1000 S16	16	100	160	16
2LEM 040 400 S06	4	40	80	6	2LEM 200 500 160	20	50	160	20
New 2LEM 045 120 S06	4.5	12	70	6	2LEM 200 600 S20	20	60	130	20
New 2LEM 045 150 S06	4.5	15	70	6	2LEM 200 1000 S20	20	100	200	20
New 2LEM 045 200 S06	4.5	20	70	6	2LEM 250 750 S25	25	75	160	25
2LEM 050 200 S06	5	20	80	6					
2LEM 050 250 S06	5	25	70	6					
2LEM 050 300 S06	5	30	75	6					
2LEM 050 400 S06	5	40	80	6					
2LEM 060 200 S06	6	20	75	6					
2LEM 060 200 100	6	20	100	6					
2LEM 060 250 S06	6	25	75	6					
2LEM 060 300 S06	6	30	80	6					
2LEM 060 350 S06	6	35	80	6					
2LEM 060 400 S06	6	40	90	6					
2LEM 060 450 S06	6	45	90	6					
2LEM 060 500 S06	6	50	100	6					

4HCE *Fraise Cylindrique 4 Coupes Serie Standard*

Fresa Cilindrica 4 Tagli Serie Standard

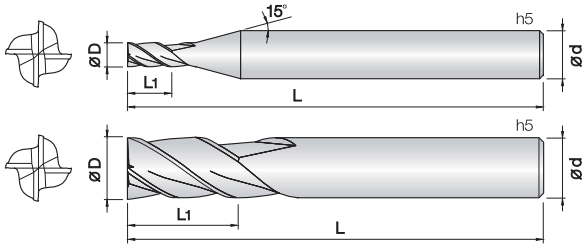

- **Fresa per acciai bonificati e temprati (HRc65)**
- Ottima resistenza all'usura grazie al nuovo rivestimento PVD a base SI.
- Elevata tolleranza del filo tagliente.
- Geometria rinforzata per prevenire scheggiature del tagliente.
- Prestazioni eccellenti in alta velocità garantite dal metallo duro Ultra Micrograna (0,2 µm).
- **Fraise pour aciers alliés et trempés jusqu'à (HRc65) de dureté.**
- Excellent contre l'usure rapide grâce au revêtement PVD à base de Si
- Tolérances élevées du diamètre et rayon, arête de coupe super finition.
- Géométrie renforcée pour prévenir de l'usure de l'arête de coupe.
- Performances excellentes à vitesse de coupe élevées.
- Carbure Submicrograin 0,2 µm.

HARD series

4

WC

TISIN

Coating

D

D

D

30°

Helix Angle

€

ø0.5 ~ 5
ø6 ~ 12
ø13 ~ 20
Rinforzato
List. p.72

d	Tolleranza/Tolérance
ø 0.5 ~ 5	+0 ~ -0.01 mm
ø 6 ~ 12	-0.01 ~ -0.025 mm
ø 13 ~ 20	-0.015 ~ -0.03 mm

Numero d'Ordine <i>Reference</i>	D	L1	L	d	Numero d'Ordine <i>Reference</i>	D	L1	L	d
New 4HCE 003 006 S04	0.3	0.6	40	4	4HCE 070 160 S08	7	16	60	8
New 4HCE 004 008 S04	0.4	0.8	40	4	4HCE 075 160 S08	7.5	16	60	8
4HCE 005 010 S04	0.5	1	40	4	4HCE 080 190 S08	8	19	60	8
4HCE 006 012 S04	0.6	1.2	40	4	4HCE 085 190 S10	8.5	19	70	10
4HCE 007 014 S04	0.7	1.4	40	4	4HCE 090 190 S10	9	19	70	10
4HCE 008 020 S04	0.8	2	40	4	4HCE 095 190 S10	9.5	19	70	10
4HCE 009 018 S04	0.9	1.8	40	4	4HCE 100 220 S10	10	22	70	10
4HCE 010 025 S03	1	2.5	40	3	4HCE 105 220 S12	10.5	22	75	12
4HCE 010 025 S04	1	2.5	40	4	4HCE 110 220 S12	11	22	75	12
4HCE 010 025 S06	1	2.5	40	6	4HCE 115 220 S12	11.5	22	75	12
4HCE 010 025 060	1	2.5	60	6	4HCE 120 260 S12	12	26	75	12
4HCE 010 025 080	1	2.5	80	6	4HCE 130 260 S14	13	26	80	14
4HCE 012 030 S03	1.2	3	40	3	4HCE 140 260 S14	14	26	80	14
4HCE 012 030 S04	1.2	3	40	4	4HCE 140 260 S16	14	26	90	16
4HCE 012 030 S06	1.2	3	40	6	4HCE 150 350 S16	15	35	100	16
4HCE 012 030 060	1.2	3	60	6	4HCE 160 350 S16	16	35	100	16
4HCE 015 040 S03	1.5	4	40	3	4HCE 170 350 S18	17	35	100	18
4HCE 015 040 S04	1.5	4	40	4	4HCE 180 350 S18	18	35	100	18
4HCE 015 040 S06	1.5	4	40	6	4HCE 200 400 S20	20	40	100	20
4HCE 015 040 060	1.5	4	60	6					
4HCE 015 040 080	1.5	4	80	6					
4HCE 020 060 S03	2	6	40	3					
4HCE 020 060 S04	2	6	40	4					
4HCE 020 060 S06	2	6	40	6					
4HCE 020 060 060	2	6	60	6					
4HCE 020 060 100	2	6	100	6					
4HCE 025 080 S03	2.5	8	45	3					
4HCE 025 080 S04	2.5	8	45	4					
4HCE 025 080 S06	2.5	8	45	6					
4HCE 025 080 070	2.5	8	70	6					
4HCE 025 080 100	2.5	8	100	6					
4HCE 030 080 S03	3	8	45	3					
4HCE 030 080 S04	3	8	45	4					
4HCE 030 080 S06	3	8	45	6					
4HCE 030 080 070	3	8	70	6					
4HCE 030 080 100	3	8	100	6					
4HCE 035 100 S06	3.5	10	45	6					
4HCE 040 110 S04	4	11	45	4					
4HCE 040 110 S06	4	11	45	6					
4HCE 040 110 070	4	11	70	6					
4HCE 040 110 100	4	11	100	6					
4HCE 045 110 S06	4.5	11	45	6					
4HCE 050 130 S06	5	13	50	6					
4HCE 050 130 080	5	13	80	6					
4HCE 050 130 100	5	13	100	6					
4HCE 055 130 S06	5.5	13	50	6					
4HCE 060 130 S06	6	13	50	6					
4HCE 060 130 080	6	13	80	6					
4HCE 060 130 100	6	13	100	6					
4HCE 065 160 S08	6.5	16	60	8					

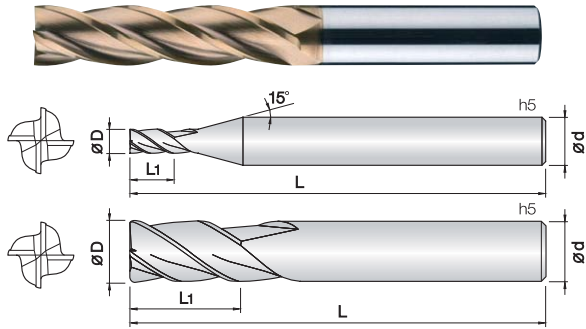

- Fresa per differenti applicazioni su vari materiali, ghisa, acciai legati, acciai bonificati e temprati fino a HRc62
- Ottima resistenza all'usura grazie al nuovo rivestimento PVD a base Si.
- Vibrazioni ridotte grazie a run-out e tolleranze precise.
- Ampia gamma di lunghezze per le più svariate applicazioni.
- Geometria rinforzata per prevenire scheggiature del tagliente.
- **Fraise pour applications sur différentes matières, fonte, aciers alliés et fortement alliés et trempés jusqu'à 62HRc.**
- Excellent contre l'usure rapide grâce au revêtement PVD à base de Si.
- Réduction de vibration et Tolérance précise.
- Gamme de longueurs importante pour plus de variante d'usinage.
- Géométrie renforcée pour prévenir de l'usure de l'arête de coupe.

4

WC
미립자

TISIN
Coating

D
+0 -0.01

D
-0.01 -0.025

D
-0.015 -0.03

30°
Helix Angle

Rinforzato

List. p.73

€

d	Tolleranza/Tolérance
ø 1 ~ 5	+0
ø 6 ~ 12	-0.01 ~ 0.025 mm
ø 14 ~ 25	-0.015 ~ 0.03 mm

Unità: mm

Numero d'Ordine Reference	D	L1	L	d	Numero d'Ordine Reference	D	L1	L	d
4LEM 005 015 S04	0.5	1.5	40	4	4LEM 050 300 S06	5	30	80	6
New 4LEM 005 020 S04	0.5	2	40	4	4LEM 050 400 S06	5	40	80	6
4LEM 006 018 S04	0.6	1.8	40	4	New 4LEM 050 500 S06	5	50	100	6
New 4LEM 006 024 S04	0.6	2.4	40	4	4LEM 060 200 S06	6	20	75	6
4LEM 008 024 S04	0.8	2.4	40	4	4LEM 060 200 100	6	20	100	6
New 4LEM 008 032 S04	0.8	3.2	40	4	4LEM 060 250 S06	6	25	75	6
4LEM 010 030 S06	1	3	60	6	4LEM 060 300 S06	6	30	80	6
4LEM 010 050 S06	1	5	60	6	4LEM 060 350 S06	6	35	80	6
4LEM 010 070 S06	1	7	60	6	4LEM 060 400 S06	6	40	90	6
4LEM 010 100 S06	1	10	60	6	4LEM 060 450 S06	6	45	90	6
4LEM 010 120 S06	1	12	60	6	4LEM 060 500 S06	6	50	100	6
New 4LEM 012 040 S06	1.2	4	60	6	4LEM 080 250 S08	8	25	75	8
New 4LEM 012 060 S06	1.2	6	60	6	4LEM 080 250 100	8	25	100	8
New 4LEM 012 080 S06	1.2	8	60	6	4LEM 080 300 S08	8	30	80	8
New 4LEM 012 100 S06	1.2	10	60	6	4LEM 080 350 S08	8	35	90	8
4LEM 015 060 S06	1.5	6	60	6	4LEM 080 400 S08	8	40	90	8
4LEM 015 080 S06	1.5	8	60	6	4LEM 080 450 S08	8	45	100	8
4LEM 015 100 S06	1.5	10	60	6	4LEM 080 500 S08	8	50	100	8
4LEM 015 120 S06	1.5	12	60	6	4LEM 080 550 S08	8	55	100	8
4LEM 015 150 S06	1.5	15	60	6	4LEM 080 600 S08	8	60	110	8
4LEM 020 080 S06	2	8	60	6	4LEM 100 300 S10	10	30	80	10
4LEM 020 100 S06	2	10	60	6	4LEM 100 300 110	10	30	110	10
4LEM 020 120 S06	2	12	60	6	4LEM 100 350 S10	10	35	90	10
4LEM 020 150 S06	2	15	60	6	4LEM 100 400 S10	10	40	90	10
New 4LEM 020 200 S06	2	20	70	6	4LEM 100 450 S10	10	45	100	10
4LEM 030 100 S06	3	10	70	6	4LEM 100 500 S10	10	50	100	10
4LEM 030 150 S06	3	15	70	6	4LEM 100 550 S10	10	55	100	10
4LEM 030 200 S06	3	20	70	6	4LEM 100 600 S10	10	60	110	10
4LEM 030 250 S06	3	25	70	6	4LEM 100 650 S10	10	65	120	10
4LEM 030 300 S06	3	30	70	6	4LEM 100 700 S10	10	70	120	10
New 4LEM 030 350 S06	3	35	75	6	4LEM 120 300 S12	12	30	90	12
New 4LEM 030 400 S06	3	40	80	6	4LEM 120 350 110	12	35	110	12
New 4LEM 035 120 S06	3.5	12	70	6	4LEM 120 400 S12	12	40	100	12
New 4LEM 035 150 S06	3.5	15	70	6	4LEM 120 450 S12	12	45	100	12
New 4LEM 035 200 S06	3.5	20	70	6	4LEM 120 500 S12	12	50	100	12
4LEM 040 120 S06	4	12	70	6	4LEM 120 550 S12	12	55	110	12
4LEM 040 150 S04	4	15	70	4	4LEM 120 600 S12	12	60	110	12
4LEM 040 150 S06	4	15	70	6	4LEM 120 700 S12	12	70	130	12
4LEM 040 200 S04	4	20	70	4	4LEM 120 800 S12	12	80	130	12
4LEM 040 200 S06	4	20	70	6	4LEM 140 500 S14	14	50	110	14
4LEM 040 250 S06	4	25	70	6	4LEM 160 400 160	16	40	160	16
4LEM 040 300 S06	4	30	75	6	4LEM 160 550 S16	16	55	120	16
4LEM 040 350 S06	4	35	75	6	4LEM 160 700 S16	16	70	130	16
4LEM 040 400 S06	4	40	80	6	4LEM 160 900 S16	16	90	150	16
New 4LEM 040 450 S06	4	45	90	6	4LEM 160 1000 S16	16	100	160	16
New 4LEM 040 500 S06	4	50	100	6	4LEM 200 500 160	20	50	160	20
New 4LEM 045 150 S06	4.5	15	70	6	4LEM 200 600 S20	20	60	130	20
New 4LEM 045 200 S06	4.5	20	70	6	4LEM 200 800 S20	20	80	160	20
4LEM 050 200 S06	5	20	70	6	4LEM 200 1000 S20	20	100	200	20
4LEM 050 250 S06	5	25	75	6	4LEM 250 750 S25	25	75	160	25

4HEM *Fraise Cylindrique 4 Coupes 45°* *Fresa Cilindrica 4 Tagli 45°*

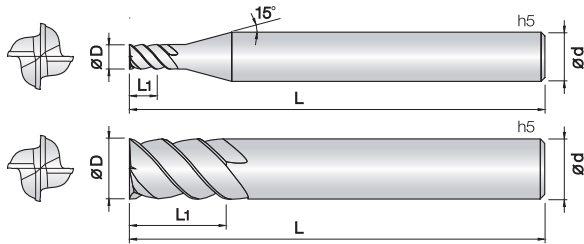

- **Fresa per acciai bonificati e temprati fino a HRc62**
- Ottima resistenza all'usura grazie al nuovo rivestimento PVD a base Si.
- Elevata tolleranza del filo tagliente.
- Elica a 45° progettata per alte velocità ed avanzamenti.
- Geometria rinforzata per prevenire scheggiature del tagliente.
- Prestazioni eccellenti in alta velocità garantite dal metallo duro Ultra Micrograna (0,2 µm).
- **Fraise pour aciers alliés et trempés jusqu'à 62HRc.**
- Excellent contre l'usure rapide grâce au revêtement PVD à base de Si
- Tolérances élevées du diamètre et rayon, arête de coupe super finition.
- Hélice a 45° permet vitesses importantes et avances rapides.
- Géométrie renforcée pour prévenir de l'usure de l'arête de coupe.
- Performances excellentes à vitesse de coupe élevées.
- Carbure Submicrograin 0,2 µm.

HARD series

4

UWC
초미립자

TISIN
Coating

D
+0 -0.01

D
-0.01 -0.025

D
-0.015 -0.03

45°
Helix Angle

Rinforzato

€
List. p.74

d	Tolleranza/Tolérance
ø 1 ~ 5	+0 ~ -0.01 mm
ø 6 ~ 12	-0.01 ~ -0.025 mm
ø 14 ~ 25	-0.015 ~ -0.03 mm

Unità: mm

Numero d'Ordine <i>Reference</i>	D	L1	L	d	Numero d'Ordine <i>Reference</i>	D	L1	L	d
4HEM 010 025 S06	1	2.5	40	6					
4HEM 010 035 S06	1	3.5	40	6					
4HEM 010 050 S06	1	5	45	6					
4HEM 012 030 S06	1.2	3	40	6					
4HEM 015 040 S06	1.5	4	40	6					
4HEM 015 060 S06	1.5	6	40	6					
4HEM 015 080 S06	1.5	8	45	6					
4HEM 020 050 S06	2	5	40	6					
4HEM 020 080 S06	2	8	45	6					
4HEM 020 100 S06	2	10	50	6					
4HEM 030 080 S06	3	8	45	6					
4HEM 030 120 S06	3	12	50	6					
4HEM 030 150 S06	3	15	55	6					
4HEM 040 110 S06	4	11	45	6					
4HEM 040 160 S06	4	16	55	6					
4HEM 040 200 S06	4	20	60	6					
4HEM 050 130 S06	5	13	50	6					
4HEM 050 180 S06	5	18	60	6					
4HEM 050 250 S06	5	25	70	6					
4HEM 060 130 S06	6	13	50	6					
4HEM 060 200 S06	6	20	60	6					
4HEM 060 250 S06	6	25	70	6					
4HEM 080 200 S08	8	20	60	8					
4HEM 080 250 S08	8	25	70	8					
4HEM 080 300 S08	8	30	75	8					
4HEM 080 400 S08	8	40	90	8					
4HEM 100 220 S10	10	22	70	10					
4HEM 100 300 S10	10	30	80	10					
4HEM 100 400 S10	10	40	90	10					
4HEM 100 500 S10	10	50	100	10					
4HEM 120 260 S12	12	26	75	12					
4HEM 120 400 S12	12	40	90	12					
4HEM 120 500 S12	12	50	100	12					
4HEM 120 600 S12	12	60	110	12					
4HEM 140 300 S14	14	30	80	14					
4HEM 140 500 S14	14	50	110	14					
4HEM 160 350 S16	16	35	90	16					
4HEM 160 500 S16	16	50	110	16					
4HEM 160 650 S16	16	65	120	16					
4HEM 200 400 S20	20	40	100	20					
4HEM 200 500 S20	20	50	110	20					
4HEM 200 700 S20	20	70	130	20					
4HEM 250 800 S25	25	80	160	25					

6&8HEM Fraise Cylindrique 6/8 Coupes Fresa Cilindrica 6/8 Tagli

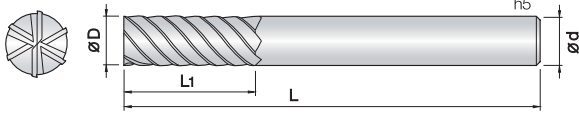

HARD series

- **Fresa per acciai bonificati e temprati fino a HRC62**
- Ottima resistenza all'usura grazie al nuovo rivestimento PVD a base Si.
- Tolleranza ed eccentricità precise garantiscono ottime finiture.
- Elica a 45° progettata per alte velocità ed avanzamenti.
- Geometria rinforzata per prevenire scheggiature.
- Prestazioni eccellenti in alta velocità garantite dal metallo duro Ultra Micrograna (0,2 µm).
- **Fraise pour aciers alliés et trempés jusqu'à 62HRC.**
- Excellent contre l'usure rapide grâce au revêtement PVD à base de Si.
- Tolérances élevées des arête de coupe.
- Hélice a 45° permet vitesses importantes et avances rapides.
- Géométrie renforcée pour prévenir de l'usure de l'arête de coupe.
- Performances excellentes à vitesse de coupe élevées.
- Carbure Submicrograin 0,2 µm.

6

8

UWC
초미립자

TISIN
Coating

D
+0 -0.01

D
-0.01 -0.025

D
-0.015 -0.03

45°
Helix Angle

€

ø3 ~ 5 ø6 ~ 12 ø16 ~ 25 List. p.75

d	Tolleranza/Tolérance
ø 3 ~ 5	+0 ~ -0.01 mm
ø 6 ~ 12	-0.01 ~ -0.025 mm
ø 16 ~ 25	-0.015 ~ -0.03 mm

Numero d'Ordine	D	L1	L	d	Numero d'Ordine	D	L1	L	d
6HEM 030 100 S06	3	10	50	6					
6HEM 030 150 S06	3	15	50	6					
6HEM 040 120 S06	4	12	50	6					
6HEM 040 160 S06	4	16	50	6					
6HEM 050 150 S06	5	15	50	6					
6HEM 050 200 S06	5	20	60	6					
6HEM 060 150 S06	6	15	50	6					
6HEM 060 200 S06	6	20	60	6					
6HEM 060 250 S06	6	25	65	6					
6HEM 060 300 S06	6	30	70	6					
6HEM 060 350 S06	6	35	75	6					
6HEM 080 200 S08	8	20	60	8					
6HEM 080 250 S08	8	25	65	8					
6HEM 080 300 S08	8	30	75	8					
6HEM 080 350 S08	8	35	80	8					
6HEM 080 400 S08	8	40	90	8					
6HEM 080 450 S08	8	45	100	8					
6HEM 080 500 S08	8	50	100	8					
6HEM 100 250 S10	10	25	70	10					
6HEM 100 350 S10	10	35	90	10					
6HEM 100 450 S10	10	45	100	10					
6HEM 100 500 S10	10	50	100	10					
6HEM 100 600 S10	10	60	110	10					
6HEM 120 300 S12	12	30	80	12					
6HEM 120 400 S12	12	40	90	12					
6HEM 120 500 S12	12	50	100	12					
6HEM 120 600 S12	12	60	110	12					
6HEM 120 700 S12	12	70	120	12					
6HEM 160 350 S16	16	35	90	16					
6HEM 160 500 S16	16	50	110	16					
6HEM 160 650 S16	16	65	120	16					
6HEM 160 800 S16	16	80	150	16					
6HEM 160 900 S16	16	90	160	16					
6HEM 160 1000 S16	16	100	160	16					
6HEM 200 450 S20	20	45	100	20					
6HEM 200 600 S20	20	60	120	20					
6HEM 200 800 S20	20	80	150	20					
6HEM 200 900 S20	20	90	160	20					
6HEM 200 1000 S20	20	100	160	20					
6HEM 200 1100 S20	20	110	170	20					
6HEM 200 1200 S20	20	120	180	20					
8HEM 250 1000 S25	25	100	160	25					
8HEM 250 1250 S25	25	125	200	25					

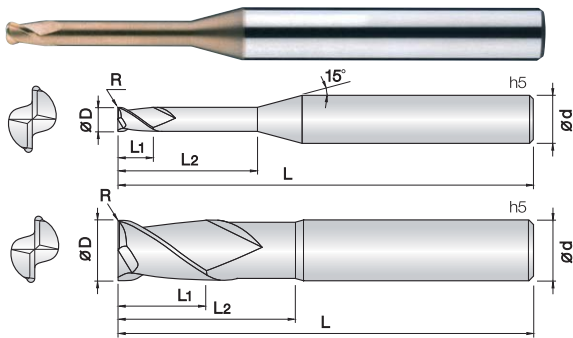

- **Fresa per acciai bonificati e temprati fino a HRc58**
- Ottima resistenza all'usura grazie al nuovo rivestimento PVD a base Si.
- Elevata tolleranza del filo tagliente.
- Progettata per ridurre scheggiature grazie allo spigolo raggiato.
- Ampia gamma di raggi e lunghezze per ottimizzare il rendimento.
- Prestazioni eccellenti in alta velocità garantite dal metallo duro Ultra Micrograna (0,2 µm).
- **Fraise pour aciers alliés et trempés jusqu'à 58HRc.**
- Excellent contre l'usure rapide grâce au revêtement PVD à base de Si.
- Tolérances élevées des arête de coupe.
- Prévu pour réduire l'usure grâce aux rayons de coupe.
- Différents rayons et longueurs pour satisfaire plusieurs applications.
- Performances excellentes à vitesse de coupe élevées.
- Carbure Submicrograin 0,2 µm.

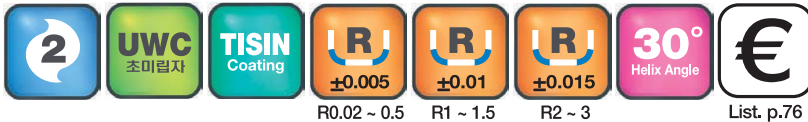

d	Tolleranza/Tolérance
∅ 0.2 ~ 5	+0 ~ -0.01 mm
∅ 6 ~ 12	-0.005 ~ -0.015 mm
∅ 16	-0.01 ~ -0.02 mm

List. p.76

Unità: mm

Numero d'Ordine Reference	D x R	L1	L2	L	d	Numero d'Ordine Reference	D x R	L1	L2	L	d
2CRE 002 0002 010	0.2 X R0.02	0.2	1	40	4	2CRE 005 001 060	0.5 X R0.1	0.5	6	45	4
2CRE 002 0002 015	0.2 X R0.02	0.2	1.5	40	4	2CRE 005 001 080	0.5 X R0.1	0.5	8	45	4
New 2CRE 002 0002 020	0.2 X R0.02	0.2	2	40	4	2CRE 005 001 100	0.5 X R0.1	0.5	10	50	4
2CRE 002 0005 010	0.2 X R0.05	0.2	1	40	4	New 2CRE 005 001 120	0.5 X R0.1	0.5	12	50	4
2CRE 002 0005 015	0.2 X R0.05	0.2	1.5	40	4	2CRE 006 0002 020	0.6 X R0.02	0.6	2	45	4
New 2CRE 002 0005 020	0.2 X R0.05	0.2	2	40	4	2CRE 006 0002 030	0.6 X R0.02	0.6	3	45	4
2CRE 003 0005 010	0.3 X R0.05	0.3	1	40	4	2CRE 006 0002 040	0.6 X R0.02	0.6	4	45	4
2CRE 003 0005 020	0.3 X R0.05	0.3	2	40	4	2CRE 006 0002 060	0.6 X R0.02	0.6	6	45	4
2CRE 003 0005 030	0.3 X R0.05	0.3	3	40	4	2CRE 006 0002 080	0.6 X R0.02	0.6	8	45	4
New 2CRE 003 0005 040	0.3 X R0.05	0.3	4	40	4	2CRE 006 0002 100	0.6 X R0.02	0.6	10	50	4
New 2CRE 003 0005 050	0.3 X R0.05	0.3	5	40	4	2CRE 006 0005 020	0.6 X R0.05	0.6	2	45	4
2CRE 004 0005 010	0.4 X R0.05	0.4	1	40	4	2CRE 006 0005 030	0.6 X R0.05	0.6	3	45	4
2CRE 004 0005 020	0.4 X R0.05	0.4	2	40	4	2CRE 006 0005 040	0.6 X R0.05	0.6	4	45	4
2CRE 004 0005 030	0.4 X R0.05	0.4	3	40	4	2CRE 006 0005 060	0.6 X R0.05	0.6	6	45	4
2CRE 004 0005 040	0.4 X R0.05	0.4	4	40	4	2CRE 006 0005 080	0.6 X R0.05	0.6	8	45	4
New 2CRE 004 0005 050	0.4 X R0.05	0.4	5	40	4	2CRE 006 0005 100	0.6 X R0.05	0.6	10	50	4
New 2CRE 004 0005 060	0.4 X R0.05	0.4	6	40	4	New 2CRE 006 0005 120	0.6 X R0.05	0.6	12	50	4
2CRE 004 001 010	0.4 X R0.1	0.4	1	40	4	2CRE 006 001 020	0.6 X R0.1	0.6	2	45	4
2CRE 004 001 015	0.4 X R0.1	0.4	1.5	40	4	2CRE 006 001 030	0.6 X R0.1	0.6	3	45	4
2CRE 004 001 020	0.4 X R0.1	0.4	2	40	4	2CRE 006 001 040	0.6 X R0.1	0.6	4	45	4
2CRE 004 001 030	0.4 X R0.1	0.4	3	40	4	2CRE 006 001 060	0.6 X R0.1	0.6	6	45	4
2CRE 004 001 040	0.4 X R0.1	0.4	4	40	4	2CRE 006 001 080	0.6 X R0.1	0.6	8	45	4
2CRE 005 0002 010	0.5 X R0.02	0.5	1	45	4	2CRE 006 001 100	0.6 X R0.1	0.6	10	50	4
2CRE 005 0002 015	0.5 X R0.02	0.5	1.5	45	4	New 2CRE 006 001 120	0.6 X R0.1	0.6	12	50	4
2CRE 005 0002 020	0.5 X R0.02	0.5	2	45	4	2CRE 007 001 020	0.7 X R0.1	0.7	2	45	4
2CRE 005 0002 025	0.5 X R0.02	0.5	2.5	45	4	2CRE 007 001 040	0.7 X R0.1	0.7	4	45	4
2CRE 005 0002 030	0.5 X R0.02	0.5	3	45	4	2CRE 007 001 060	0.7 X R0.1	0.7	6	45	4
2CRE 005 0002 040	0.5 X R0.02	0.5	4	45	4	New 2CRE 007 001 080	0.7 X R0.1	0.7	8	45	4
2CRE 005 0002 050	0.5 X R0.02	0.5	5	45	4	New 2CRE 007 001 100	0.7 X R0.1	0.7	10	45	4
2CRE 005 0002 060	0.5 X R0.02	0.5	6	45	4	2CRE 008 0002 020	0.8 X R0.02	0.8	2	45	4
2CRE 005 0002 080	0.5 X R0.02	0.5	8	45	4	2CRE 008 0002 040	0.8 X R0.02	0.8	4	45	4
2CRE 005 0002 100	0.5 X R0.02	0.5	10	50	4	2CRE 008 0002 060	0.8 X R0.02	0.8	6	45	4
2CRE 005 0005 010	0.5 X R0.05	0.5	1	45	4	2CRE 008 0002 080	0.8 X R0.02	0.8	8	45	4
2CRE 005 0005 015	0.5 X R0.05	0.5	1.5	45	4	2CRE 008 0002 100	0.8 X R0.02	0.8	10	50	4
2CRE 005 0005 020	0.5 X R0.05	0.5	2	45	4	2CRE 008 0005 020	0.8 X R0.05	0.8	2	45	4
2CRE 005 0005 025	0.5 X R0.05	0.5	2.5	45	4	2CRE 008 0005 040	0.8 X R0.05	0.8	4	45	4
2CRE 005 0005 030	0.5 X R0.05	0.5	3	45	4	2CRE 008 0005 060	0.8 X R0.05	0.8	6	45	4
2CRE 005 0005 040	0.5 X R0.05	0.5	4	45	4	2CRE 008 0005 080	0.8 X R0.05	0.8	8	45	4
2CRE 005 0005 050	0.5 X R0.05	0.5	5	45	4	2CRE 008 0005 100	0.8 X R0.05	0.8	10	50	4
2CRE 005 0005 060	0.5 X R0.05	0.5	6	45	4	New 2CRE 008 0005 120	0.8 X R0.05	0.8	12	50	4
2CRE 005 0005 080	0.5 X R0.05	0.5	8	45	4	2CRE 008 001 020	0.8 X R0.1	0.8	2	45	4
2CRE 005 0005 100	0.5 X R0.05	0.5	10	50	4	2CRE 008 001 040	0.8 X R0.1	0.8	4	45	4
New 2CRE 005 0005 120	0.5 X R0.05	0.5	12	50	4	2CRE 008 001 060	0.8 X R0.1	0.8	6	45	4
2CRE 005 001 010	0.5 X R0.1	0.5	1	45	4	2CRE 008 001 080	0.8 X R0.1	0.8	8	45	4
2CRE 005 001 015	0.5 X R0.1	0.5	1.5	45	4	2CRE 008 001 100	0.8 X R0.1	0.8	10	50	4
2CRE 005 001 020	0.5 X R0.1	0.5	2	45	4	New 2CRE 008 001 120	0.8 X R0.1	0.8	12	50	4
2CRE 005 001 025	0.5 X R0.1	0.5	2.5	45	4	New 2CRE 008 001 140	0.8 X R0.1	0.8	14	50	4
2CRE 005 001 030	0.5 X R0.1	0.5	3	45	4	2CRE 008 002 020	0.8 X R0.2	0.8	2	45	4
2CRE 005 001 040	0.5 X R0.1	0.5	4	45	4	2CRE 008 002 040	0.8 X R0.2	0.8	4	45	4
2CRE 005 001 050	0.5 X R0.1	0.5	5	45	4	2CRE 008 002 060	0.8 X R0.2	0.8	6	45	4

Numero d'Ordine Reference	D x R	L1	L2	L	d		Numero d'Ordine Reference	D x R	L1	L2	L	d	
2CRE 008 002 080	0.8 X R0.2	0.8	8	45	4		2CRE 012 003 120	1.2 X R0.3	1.2	12	50	4	
2CRE 008 002 100	0.8 X R0.2	0.8	10	50	4		New 2CRE 012 003 140	1.2 X R0.3	1.2	14	50	4	
New 2CRE 008 002 120	0.8 X R0.2	0.8	12	50	4		2CRE 012 003 160	1.2 X R0.3	1.2	16	50	4	
New 2CRE 008 002 140	0.8 X R0.2	0.8	14	50	4		2CRE 012 003 200	1.2 X R0.3	1.2	20	50	4	
2CRE 010 0005 040	1 X R0.05	1	4	45	4		2CRE 015 001 040	1.5 X R0.1	1.5	4	45	4	
2CRE 010 0005 060	1 X R0.05	1	6	45	4		2CRE 015 001 060	1.5 X R0.1	1.5	6	45	4	
2CRE 010 0005 080	1 X R0.05	1	8	45	4		2CRE 015 001 080	1.5 X R0.1	1.5	8	45	4	
2CRE 010 0005 100	1 X R0.05	1	10	50	4		2CRE 015 001 100	1.5 X R0.1	1.5	10	50	4	
2CRE 010 0005 120	1 X R0.05	1	12	50	4		2CRE 015 001 120	1.5 X R0.1	1.5	12	50	4	
New 2CRE 010 0005 140	1 X R0.05	1	14	50	4		New 2CRE 015 001 140	1.5 X R0.1	1.5	14	50	4	
2CRE 010 0005 160	1 X R0.05	1	16	50	4		2CRE 015 001 160	1.5 X R0.1	1.5	16	50	4	
2CRE 010 0005 200	1 X R0.05	1	20	50	4		2CRE 015 001 200	1.5 X R0.1	1.5	20	50	4	
2CRE 010 0005 220	1 X R0.05	1	22	60	4		2CRE 015 001 220	1.5 X R0.1	1.5	22	60	4	
2CRE 010 0005 250	1 X R0.05	1	25	60	4		2CRE 015 001 250	1.5 X R0.1	1.5	25	60	4	
2CRE 010 001 040	1 X R0.1	1	4	45	4		2CRE 015 002 040	1.5 X R0.2	1.5	4	45	4	
2CRE 010 001 060	1 X R0.1	1	6	45	4		2CRE 015 002 060	1.5 X R0.2	1.5	6	45	4	
2CRE 010 001 080	1 X R0.1	1	8	45	4		2CRE 015 002 080	1.5 X R0.2	1.5	8	45	4	
2CRE 010 001 100	1 X R0.1	1	10	50	4		2CRE 015 002 100	1.5 X R0.2	1.5	10	50	4	
2CRE 010 001 120	1 X R0.1	1	12	50	4		2CRE 015 002 120	1.5 X R0.2	1.5	12	50	4	
New 2CRE 010 001 140	1 X R0.1	1	14	50	4		New 2CRE 015 002 140	1.5 X R0.2	1.5	14	50	4	
2CRE 010 001 160	1 X R0.1	1	16	50	4		2CRE 015 002 160	1.5 X R0.2	1.5	16	50	4	
2CRE 010 001 200	1 X R0.1	1	20	50	4		2CRE 015 002 200	1.5 X R0.2	1.5	20	50	4	
2CRE 010 001 220	1 X R0.1	1	22	60	4		2CRE 015 002 220	1.5 X R0.2	1.5	22	60	4	
2CRE 010 001 250	1 X R0.1	1	25	60	4		2CRE 015 002 250	1.5 X R0.2	1.5	25	60	4	
2CRE 010 002 040	1 X R0.2	1	4	45	4		2CRE 015 003 040	1.5 X R0.3	1.5	4	45	4	
2CRE 010 002 060	1 X R0.2	1	6	45	4		2CRE 015 003 060	1.5 X R0.3	1.5	6	45	4	
2CRE 010 002 080	1 X R0.2	1	8	45	4		2CRE 015 003 080	1.5 X R0.3	1.5	8	45	4	
2CRE 010 002 100	1 X R0.2	1	10	50	4		2CRE 015 003 100	1.5 X R0.3	1.5	10	50	4	
2CRE 010 002 120	1 X R0.2	1	12	50	4		2CRE 015 003 120	1.5 X R0.3	1.5	12	50	4	
New 2CRE 010 002 140	1 X R0.2	1	14	50	4		New 2CRE 015 003 140	1.5 X R0.3	1.5	14	50	4	
2CRE 010 002 160	1 X R0.2	1	16	50	4		2CRE 015 003 160	1.5 X R0.3	1.5	16	50	4	
2CRE 010 002 200	1 X R0.2	1	20	50	4		2CRE 015 003 200	1.5 X R0.3	1.5	20	50	4	
2CRE 010 002 220	1 X R0.2	1	22	60	4		2CRE 015 003 220	1.5 X R0.3	1.5	22	60	4	
2CRE 010 002 250	1 X R0.2	1	25	60	4		2CRE 015 003 250	1.5 X R0.3	1.5	25	60	4	
2CRE 010 003 040	1 X R0.3	1	4	45	4		2CRE 015 005 040	1.5 X R0.5	1.5	4	45	4	
2CRE 010 003 060	1 X R0.3	1	6	45	4		2CRE 015 005 060	1.5 X R0.5	1.5	6	45	4	
2CRE 010 003 080	1 X R0.3	1	8	45	4		2CRE 015 005 080	1.5 X R0.5	1.5	8	45	4	
2CRE 010 003 100	1 X R0.3	1	10	50	4		2CRE 015 005 100	1.5 X R0.5	1.5	10	50	4	
2CRE 010 003 120	1 X R0.3	1	12	50	4		2CRE 015 005 120	1.5 X R0.5	1.5	12	50	4	
New 2CRE 010 003 140	1 X R0.3	1	14	50	4		New 2CRE 015 005 140	1.5 X R0.5	1.5	14	50	4	
2CRE 010 003 160	1 X R0.3	1	16	50	4		2CRE 015 005 160	1.5 X R0.5	1.5	16	50	4	
2CRE 010 003 200	1 X R0.3	1	20	50	4		2CRE 015 005 200	1.5 X R0.5	1.5	20	50	4	
2CRE 010 003 220	1 X R0.3	1	22	60	4		2CRE 015 005 220	1.5 X R0.5	1.5	22	60	4	
2CRE 010 003 250	1 X R0.3	1	25	60	4		2CRE 015 005 250	1.5 X R0.5	1.5	25	60	4	
2CRE 012 001 040	1.2 X R0.1	1.2	4	45	4		2CRE 020 001 060	2 X R0.1	2	6	45	4	
2CRE 012 001 060	1.2 X R0.1	1.2	6	45	4		2CRE 020 001 080	2 X R0.1	2	8	45	4	
2CRE 012 001 080	1.2 X R0.1	1.2	8	45	4		2CRE 020 001 100	2 X R0.1	2	10	50	4	
2CRE 012 001 100	1.2 X R0.1	1.2	10	50	4		2CRE 020 001 120	2 X R0.1	2	12	50	4	
2CRE 012 001 120	1.2 X R0.1	1.2	12	50	4		New 2CRE 020 001 140	2 X R0.1	2	14	50	4	
New 2CRE 012 001 140	1.2 X R0.1	1.2	14	50	4		2CRE 020 001 160	2 X R0.1	2	16	50	4	
2CRE 012 001 160	1.2 X R0.1	1.2	16	50	4		2CRE 020 001 200	2 X R0.1	2	20	50	4	
2CRE 012 001 200	1.2 X R0.1	1.2	20	50	4		2CRE 020 001 250	2 X R0.1	2	25	60	4	
2CRE 012 002 040	1.2 X R0.2	1.2	4	45	4		2CRE 020 001 300	2 X R0.1	2	30	70	4	
2CRE 012 002 060	1.2 X R0.2	1.2	6	45	4		New 2CRE 020 001 350	2 X R0.1	2	35	80	4	
2CRE 012 002 080	1.2 X R0.2	1.2	8	45	4		New 2CRE 020 001 400	2 X R0.1	2	40	80	4	
2CRE 012 002 100	1.2 X R0.2	1.2	10	50	4		2CRE 020 002 060	2 X R0.2	2	6	45	4	
2CRE 012 002 120	1.2 X R0.2	1.2	12	50	4		2CRE 020 002 080	2 X R0.2	2	8	45	4	
New 2CRE 012 002 140	1.2 X R0.2	1.2	14	50	4		2CRE 020 002 100	2 X R0.2	2	10	50	4	
2CRE 012 002 160	1.2 X R0.2	1.2	16	50	4		2CRE 020 002 120	2 X R0.2	2	12	50	4	
2CRE 012 002 200	1.2 X R0.2	1.2	20	50	4		New 2CRE 020 002 140	2 X R0.2	2	14	50	4	
2CRE 012 003 040	1.2 X R0.3	1.2	4	45	4		2CRE 020 002 160	2 X R0.2	2	16	50	4	
2CRE 012 003 060	1.2 X R0.3	1.2	6	45	4		2CRE 020 002 200	2 X R0.2	2	20	50	4	
2CRE 012 003 080	1.2 X R0.3	1.2	8	45	4		2CRE 020 002 250	2 X R0.2	2	25	60	4	
2CRE 012 003 100	1.2 X R0.3	1.2	10	50	4		2CRE 020 002 300	2 X R0.2	2	30	70	4	

Unità: mm

Numero d'Ordine <i>Reference</i>	D x R	L1	L2	L	d		Numero d'Ordine <i>Reference</i>	D x R	L1	L2	L	d	
2CRE 020 003 060	2 X R0.3	2	6	45	4		2CRE 030 003 350	3 X R0.3	3	35	75	6	
2CRE 020 003 080	2 X R0.3	2	8	45	4		2CRE 030 003 400	3 X R0.3	3	40	80	6	
2CRE 020 003 100	2 X R0.3	2	10	50	4		2CRE 030 005 100	3 X R0.5	3	10	50	6	
2CRE 020 003 120	2 X R0.3	2	12	50	4		2CRE 030 005 120	3 X R0.5	3	12	55	6	
New 2CRE 020 003 140	2 X R0.3	2	14	50	4		2CRE 030 005 160	3 X R0.5	3	16	55	6	
2CRE 020 003 160	2 X R0.3	2	16	50	4		2CRE 030 005 200	3 X R0.5	3	20	60	6	
2CRE 020 003 200	2 X R0.3	2	20	50	4		2CRE 030 005 250	3 X R0.5	3	25	65	6	
2CRE 020 003 250	2 X R0.3	2	25	60	4		2CRE 030 005 300	3 X R0.5	3	30	70	6	
2CRE 020 003 300	2 X R0.3	2	30	70	4		2CRE 030 005 350	3 X R0.5	3	35	75	6	
2CRE 020 005 060	2 X R0.5	2	6	45	4		2CRE 030 005 400	3 X R0.5	3	40	80	6	
2CRE 020 005 080	2 X R0.5	2	8	45	4		New 2CRE 030 005 450	3 X R0.5	3	45	90	6	
2CRE 020 005 100	2 X R0.5	2	10	50	4		New 2CRE 030 005 500	3 X R0.5	3	50	100	6	
2CRE 020 005 120	2 X R0.5	2	12	50	4		2CRE 030 010 100	3 X R1	3	10	50	6	
New 2CRE 020 005 140	2 X R0.5	2	14	50	4		2CRE 030 010 120	3 X R1	3	12	55	6	
2CRE 020 005 160	2 X R0.5	2	16	50	4		2CRE 030 010 160	3 X R1	3	16	55	6	
2CRE 020 005 200	2 X R0.5	2	20	50	4		2CRE 030 010 200	3 X R1	3	20	60	6	
2CRE 020 005 250	2 X R0.5	2	25	60	4		2CRE 030 010 250	3 X R1	3	25	65	6	
2CRE 020 005 300	2 X R0.5	2	30	70	4		2CRE 030 010 300	3 X R1	3	30	70	6	
New 2CRE 020 005 350	2 X R0.5	2	35	80	4		2CRE 030 010 350	3 X R1	3	35	75	6	
New 2CRE 020 005 400	2 X R0.5	2	40	80	4		2CRE 030 010 400	3 X R1	3	40	80	6	
2CRE 025 001 100	2.5 X R0.1	2.5	10	50	4		2CRE 040 001 050	4 X R0.1	4	12	50	4	
2CRE 025 001 160	2.5 X R0.1	2.5	16	50	4		2CRE 040 001 070	4 X R0.1	4	20	70	4	
2CRE 025 001 200	2.5 X R0.1	2.5	20	50	4		2CRE 040 001 120	4 X R0.1	4	12	55	6	
2CRE 025 001 250	2.5 X R0.1	2.5	25	60	4		2CRE 040 001 160	4 X R0.1	4	16	55	6	
2CRE 025 001 300	2.5 X R0.1	2.5	30	70	4		2CRE 040 001 200	4 X R0.1	4	20	60	6	
2CRE 025 002 100	2.5 X R0.2	2.5	10	50	4		2CRE 040 001 250	4 X R0.1	4	25	65	6	
2CRE 025 002 160	2.5 X R0.2	2.5	16	50	4		2CRE 040 001 300	4 X R0.1	4	30	70	6	
2CRE 025 002 200	2.5 X R0.2	2.5	20	50	4		2CRE 040 001 350	4 X R0.1	4	35	75	6	
2CRE 025 002 250	2.5 X R0.2	2.5	25	60	4		2CRE 040 001 400	4 X R0.1	4	40	80	6	
2CRE 025 002 300	2.5 X R0.2	2.5	30	70	4		2CRE 040 001 450	4 X R0.1	4	45	90	6	
2CRE 025 003 100	2.5 X R0.3	2.5	10	50	4		2CRE 040 001 500	4 X R0.1	4	50	100	6	
2CRE 025 003 160	2.5 X R0.3	2.5	16	50	4		2CRE 040 002 050	4 X R0.2	4	12	50	4	
2CRE 025 003 200	2.5 X R0.3	2.5	20	50	4		2CRE 040 002 070	4 X R0.2	4	20	70	4	
2CRE 025 003 250	2.5 X R0.3	2.5	25	60	4		2CRE 040 002 120	4 X R0.2	4	12	55	6	
2CRE 025 003 300	2.5 X R0.3	2.5	30	70	4		2CRE 040 002 160	4 X R0.2	4	16	55	6	
2CRE 025 005 100	2.5 X R0.5	2.5	10	50	4		2CRE 040 002 200	4 X R0.2	4	20	60	6	
2CRE 025 005 160	2.5 X R0.5	2.5	16	50	4		2CRE 040 002 250	4 X R0.2	4	25	65	6	
2CRE 025 005 200	2.5 X R0.5	2.5	20	50	4		2CRE 040 002 300	4 X R0.2	4	30	70	6	
2CRE 025 005 250	2.5 X R0.5	2.5	25	60	4		2CRE 040 002 350	4 X R0.2	4	35	75	6	
2CRE 025 005 300	2.5 X R0.5	2.5	30	70	4		2CRE 040 002 400	4 X R0.2	4	40	80	6	
2CRE 030 001 100	3 X R0.1	3	10	50	6		2CRE 040 002 450	4 X R0.2	4	45	90	6	
2CRE 030 001 120	3 X R0.1	3	12	55	6		2CRE 040 002 500	4 X R0.2	4	50	100	6	
2CRE 030 001 160	3 X R0.1	3	16	55	6		2CRE 040 003 050	4 X R0.3	4	12	50	4	
2CRE 030 001 200	3 X R0.1	3	20	60	6		2CRE 040 003 070	4 X R0.3	4	20	70	4	
2CRE 030 001 250	3 X R0.1	3	25	65	6		2CRE 040 003 120	4 X R0.3	4	12	55	6	
2CRE 030 001 300	3 X R0.1	3	30	70	6		2CRE 040 003 160	4 X R0.3	4	16	55	6	
2CRE 030 001 350	3 X R0.1	3	35	75	6		2CRE 040 003 200	4 X R0.3	4	20	60	6	
2CRE 030 001 400	3 X R0.1	3	40	80	6		2CRE 040 003 250	4 X R0.3	4	25	65	6	
2CRE 030 002 100	3 X R0.2	3	10	50	6		2CRE 040 003 300	4 X R0.3	4	30	70	6	
2CRE 030 002 120	3 X R0.2	3	12	55	6		2CRE 040 003 350	4 X R0.3	4	35	75	6	
2CRE 030 002 160	3 X R0.2	3	16	55	6		2CRE 040 003 400	4 X R0.3	4	40	80	6	
2CRE 030 002 200	3 X R0.2	3	20	60	6		2CRE 040 003 450	4 X R0.3	4	45	90	6	
2CRE 030 002 250	3 X R0.2	3	25	65	6		2CRE 040 003 500	4 X R0.3	4	50	100	6	
2CRE 030 002 300	3 X R0.2	3	30	70	6		2CRE 040 005 050	4 X R0.5	4	12	50	4	
2CRE 030 002 350	3 X R0.2	3	35	75	6		2CRE 040 005 070	4 X R0.5	4	20	70	4	
2CRE 030 002 400	3 X R0.2	3	40	80	6		2CRE 040 005 120	4 X R0.5	4	12	55	6	
New 2CRE 030 002 450	3 X R0.2	3	45	90	6		2CRE 040 005 160	4 X R0.5	4	16	55	6	
New 2CRE 030 002 500	3 X R0.2	3	50	100	6		2CRE 040 005 200	4 X R0.5	4	20	60	6	
2CRE 030 003 100	3 X R0.3	3	10	50	6		2CRE 040 005 250	4 X R0.5	4	25	65	6	
2CRE 030 003 120	3 X R0.3	3	12	55	6		2CRE 040 005 300	4 X R0.5	4	30	70	6	
2CRE 030 003 160	3 X R0.3	3	16	55	6		2CRE 040 005 350	4 X R0.5	4	35	75	6	
2CRE 030 003 200	3 X R0.3	3	20	60	6		2CRE 040 005 400	4 X R0.5	4	40	80	6	
2CRE 030 003 250	3 X R0.3	3	25	65	6		2CRE 040 005 450	4 X R0.5	4	45	90	6	
2CRE 030 003 300	3 X R0.3	3	30	70	6		2CRE 040 005 500	4 X R0.5	4	50	100	6	

HARD series

Unità: mm

HARD series

Numero d'Ordine Reference	D x R	L1	L2	L	d		Numero d'Ordine Reference	D x R	L1	L2	L	d	
2CRE 040 010 050	4 X R1	4	12	50	4		2CRE 100 015 240	10 X R1.5	11	24	70	10	
2CRE 040 010 070	4 X R1	4	20	70	4		2CRE 100 015 450	10 X R1.5	11	45	100	10	
2CRE 040 010 120	4 X R1	4	12	55	6		2CRE 100 020 240	10 X R2	11	24	70	10	
2CRE 040 010 160	4 X R1	4	16	55	6		2CRE 100 020 450	10 X R2	11	45	100	10	
2CRE 040 010 200	4 X R1	4	20	60	6		2CRE 120 002 260	12 X R0.2	13	26	80	12	
2CRE 040 010 250	4 X R1	4	25	65	6		2CRE 120 002 500	12 X R0.2	13	50	110	12	
2CRE 040 010 300	4 X R1	4	30	70	6		2CRE 120 003 260	12 X R0.3	13	26	80	12	
2CRE 040 010 350	4 X R1	4	35	75	6		2CRE 120 003 500	12 X R0.3	13	50	110	12	
2CRE 040 010 400	4 X R1	4	40	80	6		2CRE 120 005 260	12 X R0.5	13	26	80	12	
2CRE 040 010 450	4 X R1	4	45	90	6		2CRE 120 005 500	12 X R0.5	13	50	110	12	
2CRE 040 010 500	4 X R1	4	50	100	6		New 2CRE 120 005 700	12 X R0.5	13	70	130	12	
2CRE 050 002 150	5 X R0.2	6	15	60	6		2CRE 120 010 260	12 X R1	13	26	80	12	
2CRE 050 002 250	5 X R0.2	6	25	70	6		2CRE 120 010 500	12 X R1	13	50	110	12	
2CRE 050 002 300	5 X R0.2	6	30	70	6		New 2CRE 120 010 700	12 X R1	13	70	130	12	
2CRE 050 002 400	5 X R0.2	6	40	80	6		2CRE 120 015 260	12 X R1.5	13	26	80	12	
2CRE 050 002 500	5 X R0.2	6	50	100	6		2CRE 120 015 500	12 X R1.5	13	50	110	12	
2CRE 050 005 150	5 X R0.5	6	15	60	6		2CRE 120 020 260	12 X R2	13	26	80	12	
2CRE 050 005 250	5 X R0.5	6	25	70	6		2CRE 120 020 500	12 X R2	13	50	110	12	
2CRE 050 005 300	5 X R0.5	6	30	70	6		2CRE 120 030 260	12 X R3	13	26	80	12	
2CRE 050 005 400	5 X R0.5	6	40	80	6		2CRE 120 030 500	12 X R3	13	50	110	12	
2CRE 050 005 500	5 X R0.5	6	50	100	6		2CRE 160 005 110	16 X R0.5	20	40	110	16	
2CRE 050 010 150	5 X R1	6	15	60	6		2CRE 160 005 160	16 X R0.5	20	60	160	16	
2CRE 050 010 250	5 X R1	6	25	70	6		2CRE 160 010 110	16 X R1	20	40	110	16	
2CRE 050 010 300	5 X R1	6	30	70	6		2CRE 160 010 160	16 X R1	20	60	160	16	
2CRE 050 010 400	5 X R1	6	40	80	6								
2CRE 050 010 500	5 X R1	6	50	100	6								
2CRE 060 001 200	6 X R0.1	7	20	60	6								
2CRE 060 001 400	6 X R0.1	7	40	90	6								
2CRE 060 002 200	6 X R0.2	7	20	60	6								
2CRE 060 002 400	6 X R0.2	7	40	90	6								
New 2CRE 060 002 600	6 X R0.2	7	60	110	6								
2CRE 060 003 200	6 X R0.3	7	20	60	6								
2CRE 060 003 400	6 X R0.3	7	40	90	6								
2CRE 060 005 200	6 X R0.5	7	20	60	6								
2CRE 060 005 400	6 X R0.5	7	40	90	6								
New 2CRE 060 005 600	6 X R0.5	7	60	110	6								
2CRE 060 010 200	6 X R1	7	20	60	6								
2CRE 060 010 400	6 X R1	7	40	90	6								
New 2CRE 060 010 600	6 X R1	7	60	110	6								
2CRE 060 015 200	6 X R1.5	7	20	60	6								
2CRE 060 015 400	6 X R1.5	7	40	90	6								
2CRE 080 002 220	8 X R0.2	9	22	65	8								
2CRE 080 002 400	8 X R0.2	9	40	100	8								
2CRE 080 003 220	8 X R0.3	9	22	65	8								
2CRE 080 003 400	8 X R0.3	9	40	100	8								
2CRE 080 005 220	8 X R0.5	9	22	65	8								
2CRE 080 005 400	8 X R0.5	9	40	100	8								
New 2CRE 080 005 600	8 X R0.5	9	60	120	8								
2CRE 080 010 220	8 X R1	9	22	65	8								
2CRE 080 010 400	8 X R1	9	40	100	8								
New 2CRE 080 010 600	8 X R1	9	60	120	8								
2CRE 080 015 220	8 X R1.5	9	22	65	8								
2CRE 080 015 400	8 X R1.5	9	40	100	8								
2CRE 100 002 240	10 X R0.2	11	24	70	10								
2CRE 100 002 450	10 X R0.2	11	45	100	10								
New 2CRE 100 002 600	10 X R0.2	11	60	120	10								
2CRE 100 003 240	10 X R0.3	11	24	70	10								
2CRE 100 003 450	10 X R0.3	11	45	100	10								
2CRE 100 005 240	10 X R0.5	11	24	70	10								
2CRE 100 005 450	10 X R0.5	11	45	100	10								
New 2CRE 100 005 600	10 X R0.5	11	60	120	10								
2CRE 100 010 240	10 X R1	11	24	70	10								
2CRE 100 010 450	10 X R1	11	45	100	10								
New 2CRE 100 010 600	10 X R1	11	60	120	10								

4GRE *Fraise Torique 4 Coupes pour Rainurage* *Fresa Torica 4 Tagli per Nervature*

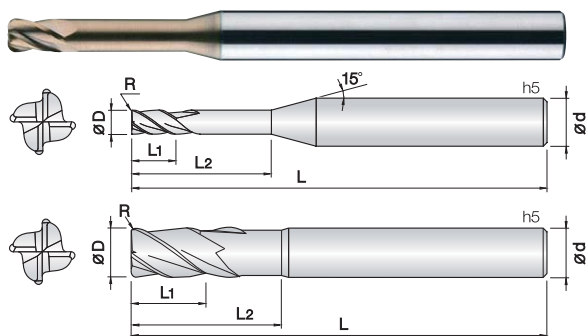

- **Fresa per acciai bonificati e temprati fino a HRC62**
- Ottima resistenza all'usura grazie al nuovo rivestimento PVD a base Si.
- Elevata tolleranza del filo tagliente.
- Progettata per ridurre scheggiature grazie allo spigolo raggiato.
- Ampia gamma di raggi e lunghezze per ottimizzare il rendimento.
- Prestazioni eccellenti in alta velocità garantite dal metallo duro Ultra Micrograna (0,2 µm).
- **Fraise pour aciers alliés et trempés jusqu'à 62HRC.**
- Excellent contre l'usure rapide grâce au revêtement PVD à base de Si.
- Tolérances élevées des arête de coupe.
- Prèvu pour réduire l'usure grâce aux rayons de coupe.
- Différents rayons et longueurs pour satisfaire plusieurs applications.
- Performances excellentes à vitesse de coupe élevées.
- Carbure Submicrograin 0,2 µm.

HARD series



R0.02 ~ 0.5

R1 ~ 1.5

R2 ~ 3

30°

Helix Angle

List. p.81

d	Tolleranza/Tolérance
Ø 0.8 ~ 5	+0 ~ -0.01 mm
Ø 6 ~ 12	-0.005 ~ -0.015 mm

Unità: mm

Numero d'Ordine Reference	D x R	L1	L2	L	d	Numero d'Ordine Reference	D x R	L1	L2	L	d
4CRE 008 0002 020	0.8 X R0.02	0.8	2	45	4	4CRE 010 0002 080	1 X R0.2	1	8	45	4
4CRE 008 0002 040	0.8 X R0.02	0.8	4	45	4	4CRE 010 0002 100	1 X R0.2	1	10	50	4
4CRE 008 0002 060	0.8 X R0.02	0.8	6	45	4	4CRE 010 0002 120	1 X R0.2	1	12	50	4
4CRE 008 0002 080	0.8 X R0.02	0.8	8	45	4	New 4CRE 010 0002 140	1 X R0.2	1	14	50	4
4CRE 008 0002 100	0.8 X R0.02	0.8	10	45	4	4CRE 010 0002 160	1 X R0.2	1	16	50	4
New 4CRE 008 0002 120	0.8 X R0.02	0.8	12	50	4	4CRE 010 0002 200	1 X R0.2	1	20	50	4
4CRE 008 0005 020	0.8 X R0.05	0.8	2	45	4	New 4CRE 010 0002 250	1 X R0.2	1	25	60	4
4CRE 008 0005 040	0.8 X R0.05	0.8	4	45	4	New 4CRE 010 0002 300	1 X R0.2	1	30	70	4
4CRE 008 0005 060	0.8 X R0.05	0.8	6	45	4	4CRE 010 0003 040	1 X R0.3	1	4	45	4
4CRE 008 0005 080	0.8 X R0.05	0.8	8	45	4	4CRE 010 0003 060	1 X R0.3	1	6	45	4
4CRE 008 0005 100	0.8 X R0.05	0.8	10	45	4	4CRE 010 0003 080	1 X R0.3	1	8	45	4
New 4CRE 008 0005 120	0.8 X R0.05	0.8	12	50	4	4CRE 010 0003 100	1 X R0.3	1	10	50	4
4CRE 008 001 020	0.8 X R0.1	0.8	2	45	4	4CRE 010 0003 120	1 X R0.3	1	12	50	4
4CRE 008 001 040	0.8 X R0.1	0.8	4	45	4	New 4CRE 010 0003 140	1 X R0.3	1	14	50	4
4CRE 008 001 060	0.8 X R0.1	0.8	6	45	4	4CRE 010 0003 160	1 X R0.3	1	16	50	4
4CRE 008 001 080	0.8 X R0.1	0.8	8	45	4	4CRE 010 0003 200	1 X R0.3	1	20	50	4
4CRE 008 001 100	0.8 X R0.1	0.8	10	45	4	New 4CRE 010 0003 250	1 X R0.3	1	25	60	4
New 4CRE 008 001 120	0.8 X R0.1	0.8	12	50	4	New 4CRE 010 0003 300	1 X R0.3	1	30	70	4
4CRE 010 0002 040	1 X R0.02	1	4	45	4	4CRE 012 0002 040	1.2 X R0.02	1.2	4	45	4
4CRE 010 0002 060	1 X R0.02	1	6	45	4	4CRE 012 0002 060	1.2 X R0.02	1.2	6	45	4
4CRE 010 0002 080	1 X R0.02	1	8	45	4	4CRE 012 0002 080	1.2 X R0.02	1.2	8	45	4
4CRE 010 0002 100	1 X R0.02	1	10	50	4	4CRE 012 0002 100	1.2 X R0.02	1.2	10	50	4
4CRE 010 0002 120	1 X R0.02	1	12	50	4	4CRE 012 0002 120	1.2 X R0.02	1.2	12	50	4
New 4CRE 010 0002 140	1 X R0.02	1	14	50	4	New 4CRE 012 0002 140	1.2 X R0.02	1.2	14	50	4
4CRE 010 0002 160	1 X R0.02	1	16	50	4	4CRE 012 0002 160	1.2 X R0.02	1.2	16	50	4
4CRE 010 0002 200	1 X R0.02	1	20	50	4	4CRE 012 0002 200	1.2 X R0.02	1.2	20	50	4
New 4CRE 010 0002 250	1 X R0.02	1	25	60	4	4CRE 012 0005 040	1.2 X R0.05	1.2	4	45	4
New 4CRE 010 0002 300	1 X R0.02	1	30	70	4	4CRE 012 0005 060	1.2 X R0.05	1.2	6	45	4
4CRE 010 0005 040	1 X R0.05	1	4	45	4	4CRE 012 0005 080	1.2 X R0.05	1.2	8	45	4
4CRE 010 0005 060	1 X R0.05	1	6	45	4	4CRE 012 0005 100	1.2 X R0.05	1.2	10	50	4
4CRE 010 0005 080	1 X R0.05	1	8	45	4	4CRE 012 0005 120	1.2 X R0.05	1.2	12	50	4
4CRE 010 0005 100	1 X R0.05	1	10	50	4	New 4CRE 012 0005 140	1.2 X R0.05	1.2	14	50	4
4CRE 010 0005 120	1 X R0.05	1	12	50	4	4CRE 012 0005 160	1.2 X R0.05	1.2	16	50	4
New 4CRE 010 0005 140	1 X R0.05	1	14	50	4	4CRE 012 0005 200	1.2 X R0.05	1.2	20	50	4
4CRE 010 0005 160	1 X R0.05	1	16	50	4	4CRE 012 001 040	1.2 X R0.1	1.2	4	45	4
4CRE 010 0005 200	1 X R0.05	1	20	50	4	4CRE 012 001 060	1.2 X R0.1	1.2	6	45	4
New 4CRE 010 0005 250	1 X R0.05	1	25	60	4	4CRE 012 001 080	1.2 X R0.1	1.2	8	45	4
New 4CRE 010 0005 300	1 X R0.05	1	30	70	4	4CRE 012 001 100	1.2 X R0.1	1.2	10	50	4
4CRE 010 001 040	1 X R0.1	1	4	45	4	4CRE 012 001 120	1.2 X R0.1	1.2	12	50	4
4CRE 010 001 060	1 X R0.1	1	6	45	4	New 4CRE 012 001 140	1.2 X R0.1	1.2	14	50	4
4CRE 010 001 080	1 X R0.1	1	8	45	4	4CRE 012 001 160	1.2 X R0.1	1.2	16	50	4
4CRE 010 001 100	1 X R0.1	1	10	50	4	4CRE 012 001 200	1.2 X R0.1	1.2	20	50	4
4CRE 010 001 120	1 X R0.1	1	12	50	4	4CRE 012 002 040	1.2 X R0.2	1.2	4	45	4
New 4CRE 010 001 140	1 X R0.1	1	14	50	4	4CRE 012 002 060	1.2 X R0.2	1.2	6	45	4
4CRE 010 001 160	1 X R0.1	1	16	50	4	4CRE 012 002 080	1.2 X R0.2	1.2	8	45	4
4CRE 010 001 200	1 X R0.1	1	20	50	4	4CRE 012 002 100	1.2 X R0.2	1.2	10	50	4
New 4CRE 010 001 250	1 X R0.1	1	25	60	4	4CRE 012 002 120	1.2 X R0.2	1.2	12	50	4
New 4CRE 010 001 300	1 X R0.1	1	30	70	4	New 4CRE 012 002 140	1.2 X R0.2	1.2	14	50	4
4CRE 010 002 040	1 X R0.2	1	4	45	4	4CRE 012 002 160	1.2 X R0.2	1.2	16	50	4
4CRE 010 002 060	1 X R0.2	1	6	45	4	4CRE 012 002 200	1.2 X R0.2	1.2	20	50	4

Numero d'Ordine Reference	D x R	L1	L2	L	d		Numero d'Ordine Reference	D x R	L1	L2	L	d	
4CRE 012 003 040	1.2 X R0.3	1.2	4	45	4		4CRE 020 0002 100	2 X R0.02	2	10	50	4	
4CRE 012 003 060	1.2 X R0.3	1.2	6	45	4		4CRE 020 0002 120	2 X R0.02	2	12	50	4	
4CRE 012 003 080	1.2 X R0.3	1.2	8	45	4		4CRE 020 0002 140	2 X R0.02	2	14	50	4	
4CRE 012 003 100	1.2 X R0.3	1.2	10	50	4		4CRE 020 0002 160	2 X R0.02	2	16	50	4	
4CRE 012 003 120	1.2 X R0.3	1.2	12	50	4		4CRE 020 0002 180	2 X R0.02	2	18	50	4	
New 4CRE 012 003 140	1.2 X R0.3	1.2	14	50	4		4CRE 020 0002 200	2 X R0.02	2	20	50	4	
4CRE 012 003 160	1.2 X R0.3	1.2	16	50	4		4CRE 020 0002 220	2 X R0.02	2	22	60	4	
4CRE 012 003 200	1.2 X R0.3	1.2	20	50	4		4CRE 020 0002 250	2 X R0.02	2	25	60	4	
4CRE 015 0002 060	1.5 X R0.02	1.5	6	45	4		4CRE 020 0002 300	2 X R0.02	2	30	70	4	
4CRE 015 0002 080	1.5 X R0.02	1.5	8	45	4		4CRE 020 0002 350	2 X R0.02	2	35	70	4	
4CRE 015 0002 100	1.5 X R0.02	1.5	10	50	4		4CRE 020 0005 060	2 X R0.05	2	6	45	4	
4CRE 015 0002 120	1.5 X R0.02	1.5	12	50	4		4CRE 020 0005 080	2 X R0.05	2	8	45	4	
New 4CRE 015 0002 140	1.5 X R0.02	1.5	14	50	4		4CRE 020 0005 100	2 X R0.05	2	10	50	4	
4CRE 015 0002 160	1.5 X R0.02	1.5	16	50	4		4CRE 020 0005 120	2 X R0.05	2	12	50	4	
4CRE 015 0002 200	1.5 X R0.02	1.5	20	50	4		4CRE 020 0005 140	2 X R0.05	2	14	50	4	
4CRE 015 0002 220	1.5 X R0.02	1.5	22	60	4		4CRE 020 0005 160	2 X R0.05	2	16	50	4	
4CRE 015 0002 250	1.5 X R0.02	1.5	25	60	4		4CRE 020 0005 180	2 X R0.05	2	18	50	4	
4CRE 015 0005 060	1.5 X R0.05	1.5	6	45	4		4CRE 020 0005 200	2 X R0.05	2	20	50	4	
4CRE 015 0005 080	1.5 X R0.05	1.5	8	45	4		4CRE 020 0005 220	2 X R0.05	2	22	60	4	
4CRE 015 0005 100	1.5 X R0.05	1.5	10	50	4		4CRE 020 0005 250	2 X R0.05	2	25	60	4	
4CRE 015 0005 120	1.5 X R0.05	1.5	12	50	4		4CRE 020 0005 300	2 X R0.05	2	30	70	4	
New 4CRE 015 0005 140	1.5 X R0.05	1.5	14	50	4		4CRE 020 0005 350	2 X R0.05	2	35	70	4	
4CRE 015 0005 160	1.5 X R0.05	1.5	16	50	4		4CRE 020 001 060	2 X R0.1	2	6	45	4	
4CRE 015 0005 200	1.5 X R0.05	1.5	20	50	4		4CRE 020 001 080	2 X R0.1	2	8	45	4	
4CRE 015 0005 220	1.5 X R0.05	1.5	22	60	4		4CRE 020 001 100	2 X R0.1	2	10	50	4	
4CRE 015 0005 250	1.5 X R0.05	1.5	25	60	4		4CRE 020 001 120	2 X R0.1	2	12	50	4	
4CRE 015 001 060	1.5 X R0.1	1.5	6	45	4		4CRE 020 001 140	2 X R0.1	2	14	50	4	
4CRE 015 001 080	1.5 X R0.1	1.5	8	45	4		4CRE 020 001 160	2 X R0.1	2	16	50	4	
4CRE 015 001 100	1.5 X R0.1	1.5	10	50	4		4CRE 020 001 180	2 X R0.1	2	18	50	4	
4CRE 015 001 120	1.5 X R0.1	1.5	12	50	4		4CRE 020 001 200	2 X R0.1	2	20	50	4	
New 4CRE 015 001 140	1.5 X R0.1	1.5	14	50	4		4CRE 020 001 220	2 X R0.1	2	22	60	4	
4CRE 015 001 160	1.5 X R0.1	1.5	16	50	4		4CRE 020 001 250	2 X R0.1	2	25	60	4	
4CRE 015 001 200	1.5 X R0.1	1.5	20	50	4		4CRE 020 001 300	2 X R0.1	2	30	70	4	
4CRE 015 001 220	1.5 X R0.1	1.5	22	60	4		4CRE 020 001 350	2 X R0.1	2	35	70	4	
4CRE 015 001 250	1.5 X R0.1	1.5	25	60	4		4CRE 020 002 060	2 X R0.2	2	6	45	4	
4CRE 015 002 060	1.5 X R0.2	1.5	6	45	4		4CRE 020 002 080	2 X R0.2	2	8	45	4	
4CRE 015 002 080	1.5 X R0.2	1.5	8	45	4		4CRE 020 002 100	2 X R0.2	2	10	50	4	
4CRE 015 002 100	1.5 X R0.2	1.5	10	50	4		4CRE 020 002 120	2 X R0.2	2	12	50	4	
4CRE 015 002 120	1.5 X R0.2	1.5	12	50	4		4CRE 020 002 140	2 X R0.2	2	14	50	4	
New 4CRE 015 002 140	1.5 X R0.2	1.5	14	50	4		4CRE 020 002 160	2 X R0.2	2	16	50	4	
4CRE 015 002 160	1.5 X R0.2	1.5	16	50	4		4CRE 020 002 180	2 X R0.2	2	18	50	4	
4CRE 015 002 200	1.5 X R0.2	1.5	20	50	4		4CRE 020 002 200	2 X R0.2	2	20	50	4	
4CRE 015 002 220	1.5 X R0.2	1.5	22	60	4		4CRE 020 002 220	2 X R0.2	2	22	60	4	
4CRE 015 002 250	1.5 X R0.2	1.5	25	60	4		4CRE 020 002 250	2 X R0.2	2	25	60	4	
4CRE 015 003 060	1.5 X R0.3	1.5	6	45	4		4CRE 020 002 300	2 X R0.2	2	30	70	4	
4CRE 015 003 080	1.5 X R0.3	1.5	8	45	4		4CRE 020 002 350	2 X R0.2	2	35	70	4	
4CRE 015 003 100	1.5 X R0.3	1.5	10	50	4		4CRE 020 003 060	2 X R0.3	2	6	45	4	
4CRE 015 003 120	1.5 X R0.3	1.5	12	50	4		4CRE 020 003 080	2 X R0.3	2	8	45	4	
New 4CRE 015 003 140	1.5 X R0.3	1.5	14	50	4		4CRE 020 003 100	2 X R0.3	2	10	50	4	
4CRE 015 003 160	1.5 X R0.3	1.5	16	50	4		4CRE 020 003 120	2 X R0.3	2	12	50	4	
4CRE 015 003 200	1.5 X R0.3	1.5	20	50	4		4CRE 020 003 140	2 X R0.3	2	14	50	4	
4CRE 015 003 220	1.5 X R0.3	1.5	22	60	4		4CRE 020 003 160	2 X R0.3	2	16	50	4	
4CRE 015 003 250	1.5 X R0.3	1.5	25	60	4		4CRE 020 003 180	2 X R0.3	2	18	50	4	
4CRE 015 005 060	1.5 X R0.5	1.5	6	45	4		4CRE 020 003 200	2 X R0.3	2	20	50	4	
4CRE 015 005 080	1.5 X R0.5	1.5	8	45	4		4CRE 020 003 220	2 X R0.3	2	22	60	4	
4CRE 015 005 100	1.5 X R0.5	1.5	10	50	4		4CRE 020 003 250	2 X R0.3	2	25	60	4	
4CRE 015 005 120	1.5 X R0.5	1.5	12	50	4		4CRE 020 003 300	2 X R0.3	2	30	70	4	
New 4CRE 015 005 140	1.5 X R0.5	1.5	14	50	4		4CRE 020 003 350	2 X R0.3	2	35	70	4	
4CRE 015 005 160	1.5 X R0.5	1.5	16	50	4		4CRE 020 005 060	2 X R0.5	2	6	45	4	
4CRE 015 005 200	1.5 X R0.5	1.5	20	50	4		4CRE 020 005 080	2 X R0.5	2	8	45	4	
4CRE 015 005 220	1.5 X R0.5	1.5	22	60	4		4CRE 020 005 100	2 X R0.5	2	10	50	4	
4CRE 015 005 250	1.5 X R0.5	1.5	25	60	4		4CRE 020 005 120	2 X R0.5	2	12	50	4	
4CRE 020 0002 060	2 X R0.02	2	6	45	4		4CRE 020 005 140	2 X R0.5	2	14	50	4	
4CRE 020 0002 080	2 X R0.02	2	8	45	4		4CRE 020 005 160	2 X R0.5	2	16	50	4	

Unità: mm

Numero d'Ordine Reference	D x R	L1	L2	L	d		Numero d'Ordine Reference	D x R	L1	L2	L	d	
4CRE 020 005 180	2 X R0.5	2	18	50	4		4CRE 030 005 400	3 X R0.5	3	40	80	6	
4CRE 020 005 200	2 X R0.5	2	20	50	4		4CRE 030 005 500	3 X R0.5	3	50	100	6	
4CRE 020 005 220	2 X R0.5	2	22	60	4		New 4CRE 030 005 600	3 X R0.5	3	60	110	6	
4CRE 020 005 250	2 X R0.5	2	25	60	4		4CRE 030 010 100	3 X R1	3	10	50	6	
4CRE 020 005 300	2 X R0.5	2	30	70	4		4CRE 030 010 120	3 X R1	3	12	50	6	
4CRE 020 005 350	2 X R0.5	2	35	70	4		4CRE 030 010 160	3 X R1	3	16	55	6	
4CRE 025 001 100	2.5 X R0.1	2.5	10	50	4		4CRE 030 010 200	3 X R1	3	20	60	6	
4CRE 025 001 120	2.5 X R0.1	2.5	12	50	4		4CRE 030 010 250	3 X R1	3	25	65	6	
4CRE 025 001 160	2.5 X R0.1	2.5	16	50	4		4CRE 030 010 300	3 X R1	3	30	70	6	
4CRE 025 001 200	2.5 X R0.1	2.5	20	50	4		4CRE 030 010 350	3 X R1	3	35	75	6	
4CRE 025 001 250	2.5 X R0.1	2.5	25	60	4		4CRE 030 010 400	3 X R1	3	40	80	6	
4CRE 025 001 300	2.5 X R0.1	2.5	30	70	4		4CRE 030 010 500	3 X R1	3	50	100	6	
4CRE 025 002 100	2.5 X R0.2	2.5	10	50	4		New 4CRE 030 010 600	3 X R1	3	60	110	6	
4CRE 025 002 120	2.5 X R0.2	2.5	12	50	4		4CRE 040 001 050	4 X R0.1	4	12	50	6	
4CRE 025 002 160	2.5 X R0.2	2.5	16	50	4		4CRE 040 001 070	4 X R0.1	4	20	70	6	
4CRE 025 002 200	2.5 X R0.2	2.5	20	50	4		4CRE 040 001 130	4 X R0.1	4	13	55	6	
4CRE 025 002 250	2.5 X R0.2	2.5	25	60	4		4CRE 040 001 160	4 X R0.1	4	16	55	6	
4CRE 025 002 300	2.5 X R0.2	2.5	30	70	4		4CRE 040 001 200	4 X R0.1	4	20	60	6	
4CRE 025 003 100	2.5 X R0.3	2.5	10	50	4		4CRE 040 001 250	4 X R0.1	4	25	65	6	
4CRE 025 003 120	2.5 X R0.3	2.5	12	50	4		4CRE 040 001 300	4 X R0.1	4	30	70	6	
4CRE 025 003 160	2.5 X R0.3	2.5	16	50	4		4CRE 040 001 350	4 X R0.1	4	35	75	6	
4CRE 025 003 200	2.5 X R0.3	2.5	20	50	4		4CRE 040 001 400	4 X R0.1	4	40	80	6	
4CRE 025 003 250	2.5 X R0.3	2.5	25	60	4		4CRE 040 001 450	4 X R0.1	4	45	90	6	
4CRE 025 003 300	2.5 X R0.3	2.5	30	70	4		4CRE 040 001 500	4 X R0.1	4	50	100	6	
4CRE 025 005 100	2.5 X R0.5	2.5	10	50	4		New 4CRE 040 001 600	4 X R0.1	4	60	110	6	
4CRE 025 005 120	2.5 X R0.5	2.5	12	50	4		4CRE 040 002 050	4 X R0.2	4	12	50	4	
4CRE 025 005 160	2.5 X R0.5	2.5	16	50	4		4CRE 040 002 070	4 X R0.2	4	20	70	4	
4CRE 025 005 200	2.5 X R0.5	2.5	20	50	4		4CRE 040 002 130	4 X R0.2	4	13	55	6	
4CRE 025 005 250	2.5 X R0.5	2.5	25	60	4		4CRE 040 002 160	4 X R0.2	4	16	55	6	
4CRE 025 005 300	2.5 X R0.5	2.5	30	70	4		4CRE 040 002 200	4 X R0.2	4	20	60	6	
4CRE 030 001 100	3 X R0.1	3	10	50	6		4CRE 040 002 250	4 X R0.2	4	25	65	6	
4CRE 030 001 120	3 X R0.1	3	12	50	6		4CRE 040 002 300	4 X R0.2	4	30	70	6	
4CRE 030 001 160	3 X R0.1	3	16	55	6		4CRE 040 002 350	4 X R0.2	4	35	75	6	
4CRE 030 001 200	3 X R0.1	3	20	60	6		4CRE 040 002 400	4 X R0.2	4	40	80	6	
4CRE 030 001 250	3 X R0.1	3	25	65	6		4CRE 040 002 450	4 X R0.2	4	45	90	6	
4CRE 030 001 300	3 X R0.1	3	30	70	6		4CRE 040 002 500	4 X R0.2	4	50	100	6	
4CRE 030 001 350	3 X R0.1	3	35	75	6		New 4CRE 040 002 600	4 X R0.2	4	60	110	6	
4CRE 030 001 400	3 X R0.1	3	40	80	6		4CRE 040 003 050	4 X R0.3	4	12	50	4	
4CRE 030 001 500	3 X R0.1	3	50	100	6		4CRE 040 003 070	4 X R0.3	4	20	70	4	
4CRE 030 002 100	3 X R0.2	3	10	50	6		4CRE 040 003 130	4 X R0.3	4	13	55	6	
4CRE 030 002 120	3 X R0.2	3	12	50	6		4CRE 040 003 160	4 X R0.3	4	16	55	6	
4CRE 030 002 160	3 X R0.2	3	16	55	6		4CRE 040 003 200	4 X R0.3	4	20	60	6	
4CRE 030 002 200	3 X R0.2	3	20	60	6		4CRE 040 003 250	4 X R0.3	4	25	65	6	
4CRE 030 002 250	3 X R0.2	3	25	65	6		4CRE 040 003 300	4 X R0.3	4	30	70	6	
4CRE 030 002 300	3 X R0.2	3	30	70	6		4CRE 040 003 350	4 X R0.3	4	35	75	6	
4CRE 030 002 350	3 X R0.2	3	35	75	6		4CRE 040 003 400	4 X R0.3	4	40	80	6	
4CRE 030 002 400	3 X R0.2	3	40	80	6		4CRE 040 003 450	4 X R0.3	4	45	90	6	
4CRE 030 002 500	3 X R0.2	3	50	100	6		4CRE 040 003 500	4 X R0.3	4	50	100	6	
4CRE 030 003 100	3 X R0.3	3	10	50	6		New 4CRE 040 003 600	4 X R0.3	4	60	110	6	
4CRE 030 003 120	3 X R0.3	3	12	50	6		4CRE 040 005 050	4 X R0.5	4	12	50	4	
4CRE 030 003 160	3 X R0.3	3	16	55	6		4CRE 040 005 070	4 X R0.5	4	20	70	4	
4CRE 030 003 200	3 X R0.3	3	20	60	6		4CRE 040 005 130	4 X R0.5	4	13	55	6	
4CRE 030 003 250	3 X R0.3	3	25	65	6		4CRE 040 005 160	4 X R0.5	4	16	55	6	
4CRE 030 003 300	3 X R0.3	3	30	70	6		4CRE 040 005 200	4 X R0.5	4	20	60	6	
4CRE 030 003 350	3 X R0.3	3	35	75	6		4CRE 040 005 250	4 X R0.5	4	25	65	6	
4CRE 030 003 400	3 X R0.3	3	40	80	6		4CRE 040 005 300	4 X R0.5	4	30	70	6	
4CRE 030 003 500	3 X R0.3	3	50	100	6		4CRE 040 005 350	4 X R0.5	4	35	75	6	
4CRE 030 005 100	3 X R0.5	3	10	50	6		4CRE 040 005 400	4 X R0.5	4	40	80	6	
4CRE 030 005 120	3 X R0.5	3	12	50	6		4CRE 040 005 450	4 X R0.5	4	45	90	6	
4CRE 030 005 160	3 X R0.5	3	16	55	6		4CRE 040 005 500	4 X R0.5	4	50	100	6	
4CRE 030 005 200	3 X R0.5	3	20	60	6		New 4CRE 040 005 600	4 X R0.5	4	60	110	6	
4CRE 030 005 250	3 X R0.5	3	25	65	6		4CRE 040 010 050	4 X R1	4	12	50	4	
4CRE 030 005 300	3 X R0.5	3	30	70	6		4CRE 040 010 070	4 X R1	4	20	70	4	
4CRE 030 005 350	3 X R0.5	3	35	75	6		4CRE 040 010 130	4 X R1	4	13	55	6	

Numero d'Ordine Reference	D x R	L1	L2	L	d		Numero d'Ordine Reference	D x R	L1	L2	L	d	
4CRE 040 010 160	4 X R1	4	16	55	6		4CRE 080 010 220	8 X R1	9	22	65	8	
4CRE 040 010 200	4 X R1	4	20	60	6		4CRE 080 010 400	8 X R1	9	40	100	8	
4CRE 040 010 250	4 X R1	4	25	65	6		4CRE 080 010 500	8 X R1	9	50	100	8	
4CRE 040 010 300	4 X R1	4	30	70	6		New 4CRE 080 010 600	8 X R1	9	60	120	8	
4CRE 040 010 350	4 X R1	4	35	75	6		4CRE 080 015 220	8 X R1.5	9	22	65	8	
4CRE 040 010 400	4 X R1	4	40	80	6		4CRE 080 015 400	8 X R1.5	9	40	100	8	
4CRE 040 010 450	4 X R1	4	45	90	6		4CRE 080 020 220	8 X R2	9	22	65	8	
4CRE 040 010 500	4 X R1	4	50	100	6		New 4CRE 080 020 400	8 X R2	9	40	100	8	
New 4CRE 040 010 600	4 X R1	4	60	110	6		4CRE 100 002 240	10 X R0.2	11	24	70	10	
4CRE 050 001 160	5 X R0.1	5	16	60	6		New 4CRE 100 002 400	10 X R0.2	11	40	100	10	
4CRE 050 001 300	5 X R0.1	5	30	70	6		4CRE 100 003 240	10 X R0.3	11	24	70	10	
4CRE 050 001 400	5 X R0.1	5	40	80	6		New 4CRE 100 003 400	10 X R0.3	11	40	100	10	
4CRE 050 001 500	5 X R0.1	5	50	100	6		4CRE 100 005 240	10 X R0.5	11	24	70	10	
4CRE 050 002 160	5 X R0.2	5	16	60	6		4CRE 100 005 400	10 X R0.5	11	40	100	10	
4CRE 050 002 300	5 X R0.2	5	30	70	6		4CRE 100 005 450	10 X R0.5	11	45	100	10	
4CRE 050 002 400	5 X R0.2	5	40	80	6		4CRE 100 005 540	10 X R0.5	11	54	110	10	
4CRE 050 002 500	5 X R0.2	5	50	100	6		New 4CRE 100 005 600	10 X R0.5	11	60	120	10	
4CRE 050 003 160	5 X R0.3	5	16	60	6		4CRE 100 010 240	10 X R1	11	24	70	10	
4CRE 050 003 300	5 X R0.3	5	30	70	6		4CRE 100 010 400	10 X R1	11	40	100	10	
4CRE 050 003 400	5 X R0.3	5	40	80	6		4CRE 100 010 450	10 X R1	11	45	110	10	
4CRE 050 003 500	5 X R0.3	5	50	100	6		4CRE 100 010 540	10 X R1	11	54	100	10	
4CRE 050 005 160	5 X R0.5	5	16	60	6		New 4CRE 100 010 600	10 X R1	11	60	120	10	
4CRE 050 005 300	5 X R0.5	5	30	70	6		4CRE 100 015 240	10 X R1.5	11	24	70	10	
4CRE 050 005 400	5 X R0.5	5	40	80	6		4CRE 100 015 400	10 X R1.5	11	40	100	10	
4CRE 050 005 500	5 X R0.5	5	50	100	6		4CRE 100 015 450	10 X R1.5	11	45	100	10	
New 4CRE 050 005 600	5 X R0.5	5	60	110	6		4CRE 100 020 240	10 X R2	11	24	70	10	
4CRE 050 010 160	5 X R1	5	16	60	6		New 4CRE 100 020 400	10 X R2	11	40	100	10	
4CRE 050 010 300	5 X R1	5	30	70	6		4CRE 100 020 450	10 X R2	11	45	70	10	
4CRE 050 010 400	5 X R1	5	40	80	6		4CRE 100 025 240	10 X R2.5	11	24	70	10	
4CRE 050 010 500	5 X R1	5	50	100	6		4CRE 120 003 260	12 X R0.3	13	26	80	12	
New 4CRE 050 010 600	5 X R1	5	60	110	6		4CRE 120 005 260	12 X R0.5	13	26	80	12	
4CRE 060 001 200	6 X R0.1	7	20	60	6		4CRE 120 005 400	12 X R0.5	13	40	110	12	
4CRE 060 001 400	6 X R0.1	7	40	80	6		4CRE 120 005 500	12 X R0.5	13	50	110	12	
4CRE 060 001 500	6 X R0.1	7	50	100	6		New 4CRE 120 005 600	12 X R0.5	13	60	130	12	
4CRE 060 002 200	6 X R0.2	7	20	60	6		4CRE 120 005 640	12 X R0.5	13	64	130	12	
4CRE 060 002 300	6 X R0.2	7	30	80	6		4CRE 120 010 260	12 X R1	13	26	80	12	
4CRE 060 002 400	6 X R0.2	7	40	80	6		4CRE 120 010 400	12 X R1	13	40	110	12	
4CRE 060 002 500	6 X R0.2	7	50	100	6		4CRE 120 010 500	12 X R1	13	50	110	12	
New 4CRE 060 002 600	6 X R0.2	7	60	110	6		New 4CRE 120 010 600	12 X R1	13	60	130	12	
4CRE 060 003 200	6 X R0.3	7	20	60	6		4CRE 120 010 640	12 X R1	13	64	130	12	
4CRE 060 003 300	6 X R0.3	7	30	80	6		4CRE 120 015 260	12 X R1.5	13	26	80	12	
4CRE 060 003 400	6 X R0.3	7	40	80	6		4CRE 120 015 400	12 X R1.5	13	40	110	12	
4CRE 060 003 500	6 X R0.3	7	50	100	6		4CRE 120 015 500	12 X R1.5	13	50	110	12	
4CRE 060 005 200	6 X R0.5	7	20	60	6		4CRE 120 020 260	12 X R2	13	26	80	12	
4CRE 060 005 300	6 X R0.5	7	30	80	6		New 4CRE 120 020 400	12 X R2	13	40	110	12	
4CRE 060 005 400	6 X R0.5	7	40	80	6		4CRE 120 020 500	12 X R2	13	50	110	12	
4CRE 060 005 500	6 X R0.5	7	50	100	6		4CRE 120 030 260	12 X R3	13	26	80	12	
New 4CRE 060 005 600	6 X R0.5	7	60	110	6		4CRE 120 030 500	12 X R3	13	50	110	12	
4CRE 060 010 200	6 X R1	7	20	60	6								
4CRE 060 010 300	6 X R1	7	30	80	6								
4CRE 060 010 400	6 X R1	7	40	80	6								
4CRE 060 010 500	6 X R1	7	50	100	6								
New 4CRE 060 010 600	6 X R1	7	60	110	6								
4CRE 060 015 200	6 X R1.5	7	20	60	6								
4CRE 060 015 400	6 X R1.5	7	40	80	6								
4CRE 060 015 500	6 X R1.5	7	50	100	6								
4CRE 080 002 220	8 X R0.2	9	22	65	8								
New 4CRE 080 002 400	8 X R0.2	9	40	100	8								
4CRE 080 003 220	8 X R0.3	9	22	65	8								
New 4CRE 080 003 400	8 X R0.3	9	40	100	8								
4CRE 080 003 500	8 X R0.3	9	50	100	8								
4CRE 080 005 220	8 X R0.5	9	22	65	8								
4CRE 080 005 400	8 X R0.5	9	40	100	8								
New 4CRE 080 005 600	8 X R0.5	9	60	120	8								

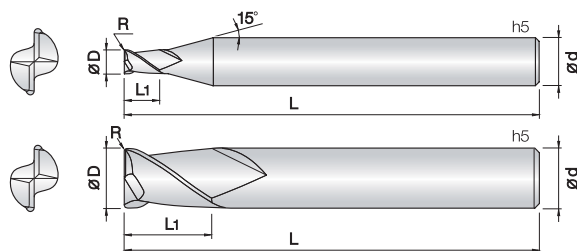

- **Fresa per acciai bonificati e temprati fino a HRc58**
- Ottima resistenza all'usura grazie al nuovo rivestimento PVD a base Si.
- Elevata tolleranza del filo tagliente.
- Progettata per ridurre scheggiature grazie allo spigolo raggiato.
- Ampia gamma di raggi e lunghezze per ottimizzare il rendimento.
- Prestazioni eccellenti in alta velocità garantite dal metallo duro Ultra Micrograna (0,2 µm).
- **Fraise pour aciers alliés et trempés jusqu'à 58HRc.**
- Excellent contre l'usure rapide grâce au revêtement PVD à base de Si.
- Tolérances élevées des arête de coupe.
- Prévu pour réduire l'usure grâce aux rayons de coupe.
- Différents rayons et longueurs pour satisfaire plusieurs applications.
- Performances excellentes à vitesse de coupe élevées.
- Carbure Submicrograin 0,2 µm.



List. p.87

d	Tolleranza/Tolérance
ø 0.2 ~ 5	+0 ~ -0.01 mm
ø 6 ~ 12	-0.005 ~ -0.015 mm

Unità: mm

Numero d'Ordine Reference	D x R	L1	L	d	Numero d'Ordine Reference	D x R	L1	L	d
2NCR 002 0002 S04	0.2 X R0.02	0.6	45	4	2NCR 025 002 S04	2.5 X R0.2	6	50	4
2NCR 002 0005 S04	0.2 X R0.05	0.6	45	4	2NCR 025 003 S04	2.5 X R0.3	6	50	4
2NCR 003 0002 S04	0.3 X R0.02	0.6	45	4	2NCR 025 004 S04	2.5 X R0.4	6	50	4
2NCR 003 0005 S04	0.3 X R0.05	0.6	45	4	2NCR 025 005 S04	2.5 X R0.5	6	50	4
2NCR 003 001 S04	0.3 X R0.1	0.6	45	4	2NCR 030 0005 S06	3 X R0.05	8	60	6
2NCR 004 0002 S04	0.4 X R0.02	0.8	45	4	2NCR 030 001 S06	3 X R0.1	8	60	6
2NCR 004 0005 S04	0.4 X R0.05	0.8	45	4	2NCR 030 002 S06	3 X R0.2	8	60	6
2NCR 004 001 S04	0.4 X R0.1	0.8	45	4	2NCR 030 003 S06	3 X R0.3	8	60	6
2NCR 005 0002 S04	0.5 X R0.02	1	45	4	2NCR 030 004 S06	3 X R0.4	8	60	6
2NCR 005 0005 S04	0.5 X R0.05	1	45	4	2NCR 030 005 S06	3 X R0.5	8	60	6
2NCR 005 001 S04	0.5 X R0.1	1	45	4	2NCR 030 010 S06	3 X R1	8	60	6
2NCR 006 0002 S04	0.6 X R0.02	1.2	45	4	2NCR 035 001 S06	3.5 X R0.1	9	70	6
2NCR 006 0005 S04	0.6 X R0.05	1.2	45	4	2NCR 035 002 S06	3.5 X R0.2	9	70	6
2NCR 006 001 S04	0.6 X R0.1	1.2	45	4	2NCR 035 003 S06	3.5 X R0.3	9	70	6
2NCR 006 002 S04	0.6 X R0.2	1.2	45	4	2NCR 035 005 S06	3.5 X R0.5	9	70	6
2NCR 007 0005 S04	0.7 X R0.05	1.4	45	4	New 2NCR 035 010 S06	3.5 X R1	9	70	6
2NCR 007 001 S04	0.7 X R0.1	1.4	45	4	2NCR 040 0005 060	4 X R0.05	9	60	4
2NCR 007 002 S04	0.7 X R0.2	1.4	45	4	2NCR 040 0005 080	4 X R0.05	9	80	4
2NCR 008 0002 S04	0.8 X R0.02	1.6	45	4	2NCR 040 0005 S06	4 X R0.05	9	70	6
2NCR 008 0005 S04	0.8 X R0.05	1.6	45	4	2NCR 040 001 060	4 X R0.1	9	60	4
2NCR 008 001 S04	0.8 X R0.1	1.6	45	4	2NCR 040 001 080	4 X R0.1	9	80	4
2NCR 008 002 S04	0.8 X R0.2	1.6	45	4	2NCR 040 001 S06	4 X R0.1	10	70	6
2NCR 009 0005 S04	0.9 X R0.05	1.8	45	4	2NCR 040 002 060	4 X R0.2	9	60	4
2NCR 009 001 S04	0.9 X R0.1	1.8	45	4	2NCR 040 002 080	4 X R0.2	9	80	4
2NCR 010 0002 S04	1 X R0.02	2.5	45	4	2NCR 040 002 S06	4 X R0.2	10	70	6
2NCR 010 0005 S04	1 X R0.05	2.5	45	4	2NCR 040 003 060	4 X R0.3	9	60	4
2NCR 010 001 S04	1 X R0.1	2.5	45	4	2NCR 040 003 080	4 X R0.3	9	80	4
2NCR 010 002 S04	1 X R0.2	2.5	45	4	2NCR 040 003 S06	4 X R0.3	10	70	6
2NCR 010 003 S04	1 X R0.3	2.5	45	4	2NCR 040 004 060	4 X R0.4	9	60	4
2NCR 010 004 S04	1 X R0.4	2.5	45	4	2NCR 040 004 080	4 X R0.4	9	80	4
2NCR 012 0005 S04	1.2 X R0.05	3.2	45	4	2NCR 040 004 S06	4 X R0.4	10	70	6
2NCR 012 001 S04	1.2 X R0.1	3.2	45	4	2NCR 040 005 060	4 X R0.5	9	60	4
2NCR 012 002 S04	1.2 X R0.2	3.2	45	4	2NCR 040 005 080	4 X R0.5	9	80	4
2NCR 012 003 S04	1.2 X R0.3	3.2	45	4	2NCR 040 005 S06	4 X R0.5	10	70	6
2NCR 015 0002 S04	1.5 X R0.02	4	45	4	2NCR 040 010 060	4 X R1	9	60	4
2NCR 015 0005 S04	1.5 X R0.05	4	45	4	2NCR 040 010 080	4 X R1	9	80	4
2NCR 015 001 S04	1.5 X R0.1	4	45	4	2NCR 040 010 S06	4 X R1	10	70	6
2NCR 015 002 S04	1.5 X R0.2	4	45	4	2NCR 045 001 S06	4.5 X R0.1	11	75	6
2NCR 015 003 S04	1.5 X R0.3	4	45	4	2NCR 045 002 S06	4.5 X R0.2	11	75	6
2NCR 015 004 S04	1.5 X R0.4	4	45	4	2NCR 045 003 S06	4.5 X R0.3	11	75	6
2NCR 015 005 S04	1.5 X R0.5	4	45	4	2NCR 045 005 S06	4.5 X R0.5	11	75	6
2NCR 020 0002 S04	2 X R0.02	6	45	4	2NCR 045 010 S06	4.5 X R1	11	75	6
2NCR 020 0005 S04	2 X R0.05	6	45	4	2NCR 050001 S06	5 X R0.1	13	75	6
2NCR 020 001 S04	2 X R0.1	6	45	4	2NCR 050 002 S06	5 X R0.2	13	75	6
2NCR 020 002 S04	2 X R0.2	6	45	4	2NCR 050 003 S06	5 X R0.3	13	75	6
2NCR 020 003 S04	2 X R0.3	6	45	4	2NCR 050 004 S06	5 X R0.4	13	75	6
2NCR 020 004 S04	2 X R0.4	6	45	4	2NCR 050 005 S06	5 X R0.5	13	75	6
2NCR 020 005 S04	2 X R0.5	6	45	4	2NCR 050 010 S06	5 X R1	13	75	6
2NCR 025 0005 S04	2.5 X R0.05	6	50	4	New 2NCR 055 002 S06	5.5 X R0.2	13	75	6
2NCR 025 001 S04	2.5 X R0.1	6	50	4	New 2NCR 055 003 S06	5.5 X R0.3	13	75	6

Unità: mm

Numero d'Ordine Reference	D x R	L1	L	d	Numero d'Ordine Reference	D x R	L1	L	d
New 2NCR 055 005 S06	5.5 X R0.5	13	75	6	2NCR 100 010 100	10 X R1	22	100	10
New 2NCR 055 010 S06	5.5 X R1	13	75	6	2NCR 100 010 130	10 X R1	22	130	10
2NCR 060 0005 060	6 X R0.05	11	60	6	2NCR 100 015 075	10 X R1.5	19	75	10
2NCR 060 0005 090	6 X R0.05	13	90	6	2NCR 100 015 100	10 X R1.5	22	100	10
2NCR 060 001 060	6 X R0.1	11	60	6	2NCR 100 015 130	10 X R1.5	22	130	10
2NCR 060 001 090	6 X R0.1	13	90	6	2NCR 100 020 075	10 X R2	19	75	10
2NCR 060 002 060	6 X R0.2	11	60	6	2NCR 100 020 100	10 X R2	22	100	10
2NCR 060 002 090	6 X R0.2	13	90	6	2NCR 100 025 100	10 X R2.5	22	100	10
2NCR 060 003 060	6 X R0.3	11	60	6	2NCR 100 030 100	10 X R3	22	100	10
2NCR 060 003 090	6 X R0.3	13	90	6	2NCR 100 040 100	10 X R4	22	100	10
2NCR 060 004 060	6 X R0.4	11	60	6	2NCR 120 001 080	12 X R0.1	22	80	12
2NCR 060 004 090	6 X R0.4	13	90	6	2NCR 120 001 110	12 X R0.1	26	110	12
2NCR 060 005 060	6 X R0.5	11	60	6	2NCR 120 002 080	12 X R0.2	22	80	12
2NCR 060 005 090	6 X R0.5	13	90	6	2NCR 120 002 110	12 X R0.2	26	110	12
2NCR 060 010 060	6 X R1	11	60	6	2NCR 120 003 080	12 X R0.3	22	80	12
2NCR 060 010 090	6 X R1	13	90	6	2NCR 120 003 110	12 X R0.3	26	110	12
2NCR 060 015 060	6 X R1.5	11	60	6	2NCR 120 005 080	12 X R0.5	22	80	12
2NCR 060 015 090	6 X R1.5	13	90	6	2NCR 120 005 110	12 X R0.5	26	110	12
2NCR 060 020 060	6 X R2	11	60	6	2NCR 120 005 130	12 X R0.5	26	130	12
2NCR 060 020 090	6 X R2	13	90	6	2NCR 120 010 080	12 X R1	22	80	12
2NCR 060 025 090	6 X R2.5	13	90	6	2NCR 120 010 110	12 X R1	26	110	12
2NCR 080 001 070	8 X R0.1	16	70	8	2NCR 120 010 130	12 X R1	26	130	12
2NCR 080 001 100	8 X R0.1	19	100	8	2NCR 120 015 080	12 X R1.5	22	80	12
2NCR 080 002 070	8 X R0.2	16	70	8	2NCR 120 015 110	12 X R1.5	26	110	12
2NCR 080 002 100	8 X R0.2	19	100	8	2NCR 120 015 130	12 X R1.5	26	130	12
2NCR 080 003 070	8 X R0.3	16	70	8	2NCR 120 020 080	12 X R2	22	80	12
2NCR 080 003 100	8 X R0.3	19	100	8	2NCR 120 020 110	12 X R2	26	110	12
2NCR 080 005 070	8 X R0.5	16	70	8	2NCR 120 020 130	12 X R2	26	130	12
2NCR 080 005 100	8 X R0.5	19	100	8	2NCR 120 025 110	12 X R2.5	26	110	12
2NCR 080 005 120	8 X R0.5	19	120	8	2NCR 120 030 110	12 X R3	26	110	12
2NCR 080 010 070	8 X R1	16	70	8	2NCR 120 040 110	12 X R4	26	110	12
2NCR 080 010 100	8 X R1	19	100	8	2NCR 120 050 110	12 X R5	26	110	12
2NCR 080 010 120	8 X R1	19	120	8	New 2NCR 140 005 110	14 X R0.5	30	110	14
2NCR 080 015 070	8 X R1.5	16	70	8	New 2NCR 140 010 110	14 X R1	30	110	14
2NCR 080 015 100	8 X R1.5	19	100	8	New 2NCR 140 020 110	14 X R2	30	110	14
2NCR 080 020 070	8 X R2	16	70	8	New 2NCR 160 005 160	16 X R0.5	32	160	16
2NCR 080 020 100	8 X R2	19	100	8	New 2NCR 160 010 160	16 X R1	32	160	16
2NCR 080 025 100	8 X R2.5	19	100	8					
2NCR 080 030 100	8 X R3	19	100	8					
2NCR 080 035 100	8 X R3.5	19	100	8					
2NCR 100 001 075	10 X R0.1	19	75	10					
2NCR 100 001 100	10 X R0.1	22	100	10					
2NCR 100 002 075	10 X R0.2	19	75	10					
2NCR 100 002 100	10 X R0.2	22	100	10					
2NCR 100 003 075	10 X R0.3	19	75	10					
2NCR 100 003 100	10 X R0.3	22	100	10					
2NCR 100 005 075	10 X R0.5	19	75	10					
2NCR 100 005 100	10 X R0.5	22	100	10					
2NCR 100 005 130	10 X R0.5	22	130	10					
2NCR 100 010 075	10 X R1	19	75	10					

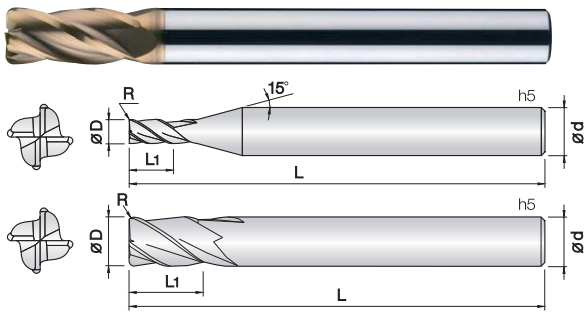

- **Fresa per acciai bonificati e temprati fino a HRc62**
- Ottima resistenza all'usura grazie al nuovo rivestimento PVD a base Si.
- Elevata tolleranza del filo tagliente.
- Progettata per ridurre scheggiature grazie allo spigolo raggiato.
- Ampia gamma di raggi e lunghezze per ottimizzare il rendimento.
- Prestazioni eccellenti in alta velocità garantite dal metallo duro Ultra Micrograna (0,2 µm).
- **Fraise pour aciers alliés et trempés jusqu'à 62HRc.**
- Excellent contre l'usure rapide grâce au revêtement PVD à base de Si.
- Tolérances élevées des arête de coupe.
- Prévu pour réduire l'usure grâce aux rayons de coupe.
- Différents rayons et longueurs pour satisfaire plusieurs applications.
- Performances excellentes à vitesse de coupe élevées.
- Carbure Submicrograin 0,2 µm.



d	Tolleranza/Tolérance
ø 1 ~ 5	+0 ~ -0.01 mm
ø 6 ~ 12	-0.005 ~ -0.015 mm
ø 16 ~ 20	-0.01 ~ -0.02 mm

List. p.90

Unità: mm

Numero d'Ordine Reference	D x R	L1	L	d	Numero d'Ordine Reference	D x R	L1	L	d
New 4NCR 005 0005 S04	0.5 X R0.05	1	45	4	4NCR 040 002 S06	4 X R0.2	10	70	6
New 4NCR 005 001 S04	0.5 X R0.1	1	45	4	4NCR 040 003 060	4 X R0.3	9	60	4
New 4NCR 006 001 S04	0.6 X R0.1	1.2	45	4	4NCR 040 003 080	4 X R0.3	9	80	4
New 4NCR 006 002 S04	0.6 X R0.2	1.2	45	4	4NCR 040 003 S06	4 X R0.3	10	70	6
New 4NCR 008 001 S04	0.8 X R0.1	1.6	45	4	4NCR 040 004 060	4 X R0.4	9	60	4
New 4NCR 008 002 S04	0.8 X R0.2	1.6	45	4	4NCR 040 004 080	4 X R0.4	9	80	4
4NCR 010 0002 S04	1 X R0.02	2.5	45	4	4NCR 040 004 S06	4 X R0.4	10	70	6
4NCR 010 0005 S04	1 X R0.05	2.5	45	4	4NCR 040 005 060	4 X R0.5	9	60	4
4NCR 010 001 S04	1 X R0.1	2.5	45	4	4NCR 040 005 080	4 X R0.5	9	80	4
4NCR 010 002 S04	1 X R0.2	2.5	45	4	4NCR 040 005 S06	4 X R0.5	10	70	6
4NCR 010 003 S04	1 X R0.3	2.5	45	4	4NCR 040 010 060	4 X R1	9	60	4
4NCR 012 0002 S04	1.2 X R0.02	4	45	4	4NCR 040 010 080	4 X R1	9	80	4
4NCR 012 0005 S04	1.2 X R0.05	4	45	4	4NCR 040 010 S06	4 X R1	10	70	6
4NCR 012 001 S04	1.2 X R0.1	4	45	4	4NCR 050 0005 S06	5 X R0.05	13	75	6
4NCR 012 002 S04	1.2 X R0.2	4	45	4	4NCR 050 001 S06	5 X R0.1	13	75	6
4NCR 012 003 S04	1.2 X R0.3	4	45	4	4NCR 050 002 S06	5 X R0.2	13	75	6
4NCR 015 0002 S04	1.5 X R0.02	4	45	4	4NCR 050 003 S06	5 X R0.3	13	75	6
4NCR 015 0005 S04	1.5 X R0.05	4	45	4	4NCR 050 004 S06	5 X R0.4	13	75	6
4NCR 015 001 S04	1.5 X R0.1	4	45	4	4NCR 050 005 S06	5 X R0.5	13	75	6
4NCR 015 002 S04	1.5 X R0.2	4	45	4	4NCR 050 010 S06	5 X R1	13	75	6
4NCR 015 003 S04	1.5 X R0.3	4	45	4	New 4NCR 055 002 S06	5.5 X R0.2	13	75	6
4NCR 015 004 S04	1.5 X R0.4	4	45	4	New 4NCR 055 003 S06	5.5 X R0.3	13	75	6
4NCR 015 005 S04	1.5 X R0.5	4	45	4	New 4NCR 055 005 S06	5.5 X R0.5	13	75	6
4NCR 020 0002 S04	2 X R0.02	6	45	4	New 4NCR 055 010 S06	5.5 X R1	13	75	6
4NCR 020 0005 S04	2 X R0.05	6	45	4	4NCR 060 0005 080	6 X R0.05	13	80	6
4NCR 020 001 S04	2 X R0.1	6	45	4	4NCR 060 001 060	6 X R0.1	11	60	6
4NCR 020 002 S04	2 X R0.2	6	45	4	4NCR 060 001 080	6 X R0.1	13	80	6
4NCR 020 003 S04	2 X R0.3	6	45	4	4NCR 060 002 060	6 X R0.2	11	60	6
4NCR 020 004 S04	2 X R0.4	6	45	4	4NCR 060 002 080	6 X R0.2	13	80	6
4NCR 020 005 S04	2 X R0.5	6	45	4	4NCR 060 003 060	6 X R0.3	11	60	6
4NCR 025 0005 S04	2.5 X R0.05	6	50	4	4NCR 060 003 080	6 X R0.3	13	80	6
4NCR 025 001 S04	2.5 X R0.1	6	50	4	4NCR 060 004 080	6 X R0.4	13	80	6
4NCR 025 002 S04	2.5 X R0.2	6	50	4	4NCR 060 005 060	6 X R0.5	11	60	6
4NCR 025 003 S04	2.5 X R0.3	6	50	4	4NCR 060 005 080	6 X R0.5	13	80	6
4NCR 025 005 S04	2.5 X R0.5	6	50	4	4NCR 060 010 060	6 X R1	11	60	6
4NCR 030 0005 S06	3 X R0.05	8	60	6	4NCR 060 010 080	6 X R1	13	80	6
4NCR 030 001 S06	3 X R0.1	8	60	6	4NCR 060 015 060	6 X R1.5	11	60	6
4NCR 030 002 S06	3 X R0.2	8	60	6	4NCR 060 015 080	6 X R1.5	13	80	6
4NCR 030 003 S06	3 X R0.3	8	60	6	4NCR 060 020 060	6 X R2	11	60	6
4NCR 030 004 S06	3 X R0.4	8	60	6	4NCR 060 020 080	6 X R2	13	80	6
4NCR 030 005 S06	3 X R0.5	8	60	6	4NCR 080 001 070	8 X R0.1	16	70	8
4NCR 030 010 S06	3 X R1	8	60	6	4NCR 080 001 090	8 X R0.1	19	90	8
4NCR 040 0005 060	4 X R0.05	9	60	4	4NCR 080 002 070	8 X R0.2	16	70	8
4NCR 040 0005 080	4 X R0.05	9	80	4	4NCR 080 002 090	8 X R0.2	19	90	8
4NCR 040 0005 S06	4 X R0.05	10	70	6	4NCR 080 003 070	8 X R0.3	16	70	8
4NCR 040 001 060	4 X R0.1	9	60	4	4NCR 080 003 090	8 X R0.3	19	90	8
4NCR 040 001 080	4 X R0.1	9	80	4	4NCR 080 005 070	8 X R0.5	16	70	8
4NCR 040 001 S06	4 X R0.1	10	70	6	4NCR 080 005 090	8 X R0.5	19	90	8
4NCR 040 002 060	4 X R0.2	9	60	4	4NCR 080 005 110	8 X R0.5	19	110	8
4NCR 040 002 080	4 X R0.2	9	80	4	4NCR 080 010 070	8 X R1	16	70	8

Unità: mm

Numero d'Ordine Reference	D x R	L1	L	d		Numero d'Ordine Reference	D x R	L1	L	d	
4NCR 080 010 090	8 X R1	19	90	8		4NCR 120 025 110	12 X R2.5	26	110	12	
4NCR 080 010 110	8 X R1	19	110	8		4NCR 120 025 130	12 X R2.5	26	130	12	
4NCR 080 015 070	8 X R1.5	16	70	8		4NCR 120 030 080	12 X R3	22	80	12	
4NCR 080 015 090	8 X R1.5	19	90	8		4NCR 120 030 110	12 X R3	26	110	12	
4NCR 080 015 110	8 X R1.5	19	110	8		4NCR 120 030 130	12 X R3	26	130	12	
4NCR 080 020 070	8 X R2	16	70	8		4NCR 120 035 110	12 X R3.5	26	110	12	
4NCR 080 020 090	8 X R2	19	90	8		4NCR 120 040 110	12 X R4	26	110	12	
4NCR 080 020 110	8 X R2	19	110	8		New 4NCR 140 005 110	14 X R0.5	30	110	14	
4NCR 080 025 090	8 X R2.5	19	90	8		New 4NCR 140 010 110	14 X R1	30	110	14	
4NCR 100 001 075	10 X R0.1	19	75	10		New 4NCR 140 020 110	14 X R2	30	110	14	
4NCR 100 001 100	10 X R0.1	22	100	10		4NCR 160 005 110	16 X R0.5	32	110	16	
4NCR 100 002 075	10 X R0.2	19	75	10		4NCR 160 005 160	16 X R0.5	32	160	16	
4NCR 100 002 100	10 X R0.2	22	100	10		4NCR 160 010 110	16 X R1	32	110	16	
4NCR 100 002 120	10 X R0.2	22	120	10		4NCR 160 010 160	16 X R1	32	160	16	
4NCR 100 003 075	10 X R0.3	19	75	10		4NCR 160 015 110	16 X R1.5	32	110	16	
4NCR 100 003 100	10 X R0.3	22	100	10		4NCR 160 020 110	16 X R2	32	110	16	
4NCR 100 005 075	10 X R0.5	19	75	10		4NCR 160 030 110	16 X R3	32	110	16	
4NCR 100 005 100	10 X R0.5	22	100	10		4NCR 200 005 160	20 X R0.5	38	160	20	
4NCR 100 005 120	10 X R0.5	22	120	10		4NCR 200 010 160	20 X R1	38	160	20	
4NCR 100 010 075	10 X R1	19	75	10		4NCR 200 015 160	20 X R1.5	38	160	20	
4NCR 100 010 100	10 X R1	22	100	10		4NCR 200 020 160	20 X R2	38	160	20	
4NCR 100 010 120	10 X R1	22	120	10							
4NCR 100 015 075	10 X R1.5	19	75	10							
4NCR 100 015 100	10 X R1.5	22	100	10							
4NCR 100 015 120	10 X R1.5	22	120	10							
4NCR 100 020 075	10 X R2	19	75	10							
4NCR 100 020 100	10 X R2	22	100	10							
4NCR 100 020 120	10 X R2	22	120	10							
4NCR 100 025 075	10 X R2.5	19	75	10							
4NCR 100 025 100	10 X R2.5	22	100	10							
4NCR 100 025 120	10 X R2.5	22	120	10							
4NCR 100 030 100	10 X R3	22	100	10							
4NCR 120 002 080	12 X R0.2	22	80	12							
4NCR 120 002 110	12 X R0.2	26	110	12							
4NCR 120 002 130	12 X R0.2	26	130	12							
4NCR 120 003 080	12 X R0.3	22	80	12							
4NCR 120 003 110	12 X R0.3	26	110	12							
4NCR 120 005 080	12 X R0.5	22	80	12							
4NCR 120 005 110	12 X R0.5	26	110	12							
4NCR 120 005 130	12 X R0.5	26	130	12							
4NCR 120 010 080	12 X R1	22	80	12							
4NCR 120 010 110	12 X R1	26	110	12							
4NCR 120 010 130	12 X R1	26	130	12							
4NCR 120 015 080	12 X R1.5	22	80	12							
4NCR 120 015 110	12 X R1.5	26	110	12							
4NCR 120 015 130	12 X R1.5	26	130	12							
4NCR 120 020 080	12 X R2	22	80	12							
4NCR 120 020 110	12 X R2	26	110	12							
4NCR 120 020 130	12 X R2	26	130	12							
4NCR 120 025 080	12 X R2.5	22	80	12							

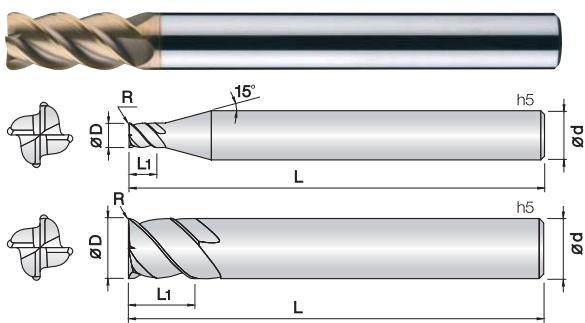

- **Fresa per acciai bonificati e temprati fino a HRc62**
- Ottima resistenza all'usura grazie al nuovo rivestimento PVD a base Si.
- Elevata tolleranza del filo tagliente.
- Progettata per ridurre scheggiature grazie allo spigolo raggiato.
- Elica a 45° progettata per alte velocità ed avanzamenti.
- Prestazioni eccellenti in alta velocità garantite dal metallo duro Ultra Micrograna (0,2 µm).
- **Fraise pour aciers alliés et trempés jusqu'à 62HRc.**
- Excellent contre l'usure rapide grâce au revêtement PVD à base de Si.
- Tolérances élevées des arête de coupe.
- Prêvu pour réduire l'usure grâce aux rayons de coupe.
- Hélice a 45° permet vitesses importantes et avances importantes.
- Performances excellentes à vitesse de coupe élevées.
- Carbure Submicrograin 0,2 µm.



R0.05 ~ 0.5

R1 ~ 1.5

R2 ~ 5

List. p.92

d	Tolleranza/Tolérance
Ø 1 ~ 4	+0 ~ -0.01 mm
Ø 6 ~ 12	-0.005 ~ -0.015 mm
Ø 16 ~ 20	-0.01 ~ -0.02 mm

Unità: mm

Numero d'Ordine Reference	D x R	L1	L	d	Numero d'Ordine Reference	D x R	L1	L	d
4CRL 010 0005 S06	1 X R0.05	2	50	6	4CRL 100 003 S10	10 X R0.3	20	100	10
4CRL 010 001 S06	1 X R0.1	2	50	6	4CRL 100 005 S10	10 X R0.5	20	100	10
4CRL 010 002 S06	1 X R0.2	2	50	6	4CRL 100 010 S10	10 X R1	20	100	10
4CRL 010 003 S06	1 X R0.3	2	50	6	4CRL 100 015 S10	10 X R1.5	20	100	10
4CRL 012 0005 S06	1.2 X R0.05	2.5	50	6	4CRL 100 020 S10	10 X R2	20	100	10
4CRL 012 001 S06	1.2 X R0.1	2.5	50	6	4CRL 120 003 S12	12 X R0.3	24	110	12
4CRL 012 002 S06	1.2 X R0.2	2.5	50	6	4CRL 120 005 S12	12 X R0.5	24	110	12
4CRL 012 003 S06	1.2 X R0.3	2.5	50	6	4CRL 120 010 S12	12 X R1	24	110	12
4CRL 015 0005 S06	1.5 X R0.05	3	50	6	4CRL 120 015 S12	12 X R1.5	24	110	12
4CRL 015 001 S06	1.5 X R0.1	3	50	6	4CRL 120 020 S12	12 X R2	24	110	12
4CRL 015 002 S06	1.5 X R0.2	3	50	6	4CRL 120 030 S12	12 X R3	24	110	12
4CRL 015 003 S06	1.5 X R0.3	3	50	6	4CRL 160 005 S16	16 X R0.5	32	120	16
4CRL 015 005 S06	1.5 X R0.5	3	50	6	4CRL 160 010 S16	16 X R1	32	120	16
4CRL 020 001 S06	2 X R0.1	5	50	6	4CRL 160 020 S16	16 X R2	32	120	16
4CRL 020 002 S06	2 X R0.2	5	50	6	4CRL 160 030 S16	16 X R3	32	120	16
4CRL 020 003 S06	2 X R0.3	5	50	6	4CRL 200 005 S20	20 X R0.5	38	130	20
4CRL 020 005 S06	2 X R0.5	5	50	6	4CRL 200 010 S20	20 X R1	38	130	20
4CRL 025 001 S06	2.5 X R0.1	6	60	6	4CRL 200 020 S20	20 X R2	38	130	20
4CRL 025 002 S06	2.5 X R0.2	6	60	6	4CRL 200 030 S20	20 X R3	38	130	20
4CRL 025 003 S06	2.5 X R0.3	6	60	6	4CRL 200 040 S20	20 X R4	38	130	20
4CRL 025 005 S06	2.5 X R0.5	6	60	6	4CRL 200 050 S20	20 X R5	38	130	20
4CRL 030 001 S06	3 X R0.1	6	70	6					
4CRL 030 002 S06	3 X R0.2	6	70	6					
4CRL 030 003 S06	3 X R0.3	6	70	6					
4CRL 030 005 S06	3 X R0.5	6	70	6					
4CRL 030 010 S06	3 X R1	6	70	6					
4CRL 040 001 S06	4 X R0.1	8	70	6					
4CRL 040 002 S06	4 X R0.2	8	70	6					
4CRL 040 003 S06	4 X R0.3	8	70	6					
4CRL 040 005 S06	4 X R0.5	8	70	6					
4CRL 040 010 S06	4 X R1	8	70	6					
New 4CRL 050 001 S06	5 X R0.1	10	80	6					
New 4CRL 050 002 S06	5 X R0.2	10	80	6					
New 4CRL 050 003 S06	5 X R0.3	10	80	6					
New 4CRL 050 005 S06	5 X R0.5	10	80	6					
New 4CRL 050 010 S06	5 X R1	10	80	6					
4CRL 060 001 S06	6 X R0.1	12	90	6					
4CRL 060 002 S06	6 X R0.2	12	90	6					
4CRL 060 003 S06	6 X R0.3	12	90	6					
4CRL 060 005 S06	6 X R0.5	12	90	6					
4CRL 060 010 S06	6 X R1	12	90	6					
4CRL 060 015 S06	6 X R1.5	12	90	6					
4CRL 060 020 S06	6 X R2	12	90	6					
4CRL 080 002 S08	8 X R0.2	16	90	8					
4CRL 080 003 S08	8 X R0.3	16	90	8					
4CRL 080 005 S08	8 X R0.5	16	90	8					
4CRL 080 010 S08	8 X R1	16	90	8					
4CRL 080 015 S08	8 X R1.5	16	90	8					
4CRL 080 020 S08	8 X R2	16	90	8					
4CRL 100 002 S10	10 X R0.2	20	100	10					

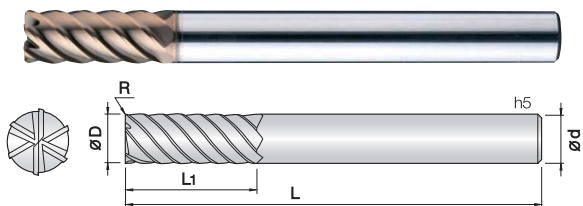

- **Fresa per acciai bonificati e temprati fino a HRC62**
- Ottima resistenza all'usura grazie al nuovo rivestimento PVD a base Si.
- Elica a 45° progettata per alte velocità ed avanzamenti.
- Il nuovo profilo migliora la resistenza all'usura e permette eccellenti finiture in svariate applicazioni.
- Prestazioni eccellenti in alta velocità garantite dal metallo duro Ultra Micrograna (0,2 µm).
- **Fraise pour aciers alliés et trempés jusqu'à 62HRC.**
- Excellent contre l'usure rapide grâce au revêtement PVD à base de Si.
- Tolérances élevées des arête de coupe.
- Prêvu pour réduire l'usure grâce aux rayons de coupe.
- Hélice a 45° permet vitesses importantes et avances importantes.
- Performances excellentes à vitesse de coupe élevées.
- Carbure Submicrograin 0,2 µm.



d	Tolleranza/Tolérance
ø 5	+0 ~ -0.01 mm
ø 6 ~ 12	-0.005 ~ -0.015 mm
ø 16	-0.01 ~ -0.02 mm

List. p.93

Unità: mm

Numero d'Ordine Reference	D x R	L1	L	d	Numero d'Ordine Reference	D x R	L1	L	d
6CRL 030 001 060	3 X R0.1	7.5	60	6					
6CRL 030 002 060	3 X R0.2	7.5	60	6					
6CRL 030 003 060	3 X R0.3	7.5	60	6					
6CRL 030 005 060	3 X R0.5	7.5	60	6					
6CRL 030 010 060	3 X R1	7.5	60	6					
6CRL 040 001 060	4 X R0.1	10	60	6					
6CRL 040 002 060	4 X R0.2	10	60	6					
6CRL 040 003 060	4 X R0.3	10	60	6					
6CRL 040 005 060	4 X R0.5	10	60	6					
6CRL 040 010 060	4 X R1	10	60	6					
6CRL 050 002 060	5 X R0.2	13	60	6					
6CRL 050 003 060	5 X R0.3	13	60	6					
6CRL 050 005 060	5 X R0.5	13	60	6					
6CRL 050 010 060	5 X R1	13	60	6					
6CRL 060 001 060	6 X R0.1	15	60	6					
6CRL 060 002 060	6 X R0.2	15	60	6					
6CRL 060 002 080	6 X R0.2	15	80	6					
6CRL 060 003 060	6 X R0.3	15	60	6					
6CRL 060 003 080	6 X R0.3	15	80	6					
6CRL 060 005 060	6 X R0.5	15	60	6					
6CRL 060 005 080	6 X R0.5	15	80	6					
6CRL 060 010 060	6 X R1	15	60	6					
6CRL 060 010 080	6 X R1	15	80	6					
6CRL 080 002 070	8 X R0.2	20	70	8					
6CRL 080 003 070	8 X R0.3	20	70	8					
6CRL 080 003 090	8 X R0.3	20	90	8					
6CRL 080 005 070	8 X R0.5	20	70	8					
6CRL 080 005 090	8 X R0.5	20	90	8					
6CRL 080 010 070	8 X R1	20	70	8					
6CRL 080 010 090	8 X R1	20	90	8					
6CRL 080 015 070	8 X R1.5	20	70	8					
6CRL 100 002 075	10 X R0.2	20	75	10					
6CRL 100 003 075	10 X R0.3	25	75	10					
6CRL 100 003 100	10 X R0.3	25	100	10					
6CRL 100 005 075	10 X R0.5	25	75	10					
6CRL 100 005 100	10 X R0.5	25	100	10					
6CRL 100 010 075	10 X R1	25	75	10					
6CRL 100 010 100	10 X R1	25	100	10					
6CRL 100 020 075	10 X R2	25	75	10					
6CRL 120 002 080	12 X R0.2	25	80	12					
6CRL 120 003 080	12 X R0.3	30	80	12					
6CRL 120 003 110	12 X R0.3	30	110	12					
6CRL 120 005 080	12 X R0.5	30	80	12					
6CRL 120 005 110	12 X R0.5	30	110	12					
6CRL 120 010 080	12 X R1	30	80	12					
6CRL 120 010 110	12 X R1	30	110	12					
6CRL 120 020 080	12 X R2	30	80	12					
6CRL 160 005 110	16 X R0.5	50	110	16					
6CRL 160 010 110	16 X R1	50	110	16					
6CRL 160 020 110	16 X R2	50	110	16					

4RCU *Fraise Torique 4 Coupes pour Grande Avance* *Fresa Torica 4 Tagli per Alti Avanzamenti*

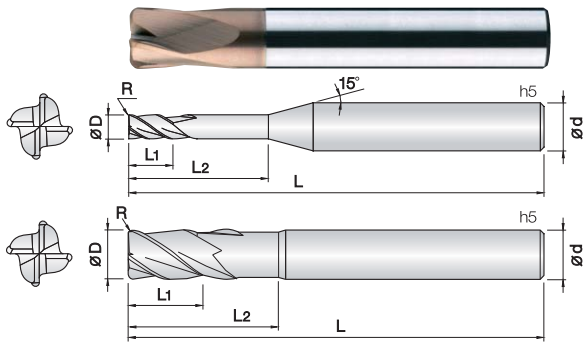

R0.2 ~ 0.5

R1 ~ 1.5

R2 ~ 3

List. p.94

- **Fresa per acciai bonificati e temprati fino a HRc62**
- Ottima resistenza all'usura grazie al nuovo rivestimento PVD a base Si.
- Progettata per utilizzo con alti avanzamenti.
- Indicata per lavorazioni gravose e di sgrossatura.
- Riduzioni di sheggiature ad alti avanzamenti garantite dal metallo duro Ultra Micrograna (0,2 µm).
- **Fraise pour aciers alliés et trempés jusqu'à 62HRc.**
- *Excellent contre l'usure rapide grâce au revêtement PVD à base de Si.*
- *Coupe prévu pour l'usinage grande avance.*
- *Coupe prévu pour l'usinage dans des conditions difficiles et d'ébauche.*
- *Réduction d'usure à grande avance.*
- *Carbure Submicrograin 0,2 µm.*

d	Tolleranza/Tolérance
ø 1 ~ 5	+0 ~ -0.01 mm
ø 6 ~ 12	-0.005 ~ -0.015 mm
ø 16	-0.01 ~ -0.02 mm

Numero d'Ordine Reference	D x R	L1	L2	L	d	Numero d'Ordine Reference	D x R	L1	L2	L	d
4RCU 010 002 025	1 X R0.2	1	2.5	50	4						
4RCU 015 005 040	1.5 X R0.5	1.5	4	50	4						
4RCU 020 005 060	2 X R0.5	2	6	50	6						
4RCU 030 005 080	3 X R0.5	3	8	50	6						
4RCU 040 005 120	4 X R0.5	4	12	60	6						
4RCU 040 005 160	4 X R0.5	4	16	60	6						
4RCU 040 010 120	4 X R1	4	12	60	6						
4RCU 040 010 160	4 X R1	4	16	60	6						
4RCU 050 005 150	5 X R0.5	5	15	60	6						
4RCU 050 010 150	5 X R1	5	15	60	6						
4RCU 060 003 150	6 X R0.3	6	15	60	6						
4RCU 060 005 150	6 X R0.5	6	15	60	6						
4RCU 060 010 150	6 X R1	6	15	60	6						
4RCU 060 015 150	6 X R1.5	6	15	60	6						
4RCU 080 003 160	8 X R0.3	8	16	60	8						
4RCU 080 005 160	8 X R0.5	8	16	60	8						
4RCU 080 005 200	8 X R0.5	8	20	80	8						
4RCU 080 005 300	8 X R0.5	8	30	110	8						
4RCU 080 010 160	8 X R1	8	16	60	8						
4RCU 080 010 200	8 X R1	8	20	80	8						
4RCU 080 010 300	8 X R1	8	30	110	8						
4RCU 080 020 160	8 X R2	8	16	60	8						
4RCU 080 020 200	8 X R2	8	20	80	8						
4RCU 080 020 300	8 X R2	8	30	110	8						
4RCU 100 003 200	10 X R0.3	10	20	70	10						
4RCU 100 005 200	10 X R0.5	10	20	70	10						
4RCU 100 005 250	10 X R0.5	10	25	90	10						
4RCU 100 005 300	10 X R0.5	10	30	120	10						
4RCU 100 010 200	10 X R1	10	20	70	10						
4RCU 100 010 250	10 X R1	10	25	90	10						
4RCU 100 010 300	10 X R1	10	30	120	10						
4RCU 100 020 200	10 X R2	10	20	70	10						
4RCU 100 020 250	10 X R2	10	25	90	10						
4RCU 100 020 300	10 X R2	10	30	120	10						
4RCU 120 005 250	12 X R0.5	12	25	80	12						
4RCU 120 005 300	12 X R0.5	12	30	100	12						
4RCU 120 005 350	12 X R0.5	12	35	130	12						
4RCU 120 010 250	12 X R1	12	25	80	12						
4RCU 120 010 300	12 X R1	12	30	100	12						
4RCU 120 010 350	12 X R1	12	35	130	12						
4RCU 120 020 250	12 X R2	12	25	80	12						
4RCU 120 020 300	12 X R2	12	30	100	12						
4RCU 120 020 350	12 X R2	12	35	130	12						
4RCU 120 030 250	12 X R3	12	25	80	12						
4RCU 160 010 300	16 X R1	16	30	110	16						
4RCU 160 010 400	16 X R1	16	40	160	16						
4RCU 160 020 300	16 X R2	16	30	110	16						
4RCU 160 020 400	16 X R2	16	40	160	16						

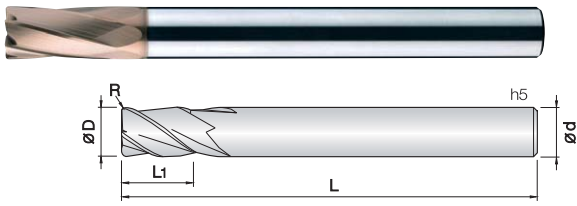

- **Fresa per acciai bonificati e temprati fino a HRc62**
- Ottima resistenza all'usura grazie al nuovo rivestimento PVD a base Si.
- Progettata per utilizzo con alti avanzamenti.
- Indicata per lavorazioni gravose e di sgrossatura.
- Riduzioni di sheggiature ad alti avanzamenti garantite dal metallo duro Ultra Micrograna (0,2 µm).
- **Fraise pour aciers alliés et trempés jusqu'à 62HRc.**
- Excellent contre l'usure rapide grâce au revêtement PVD à base de Si.
- Coupe prévu pour l'usinage grande avance.
- Coupe prévu pour l'usinage dans des conditions difficiles et d'ébauche.
- Réduction d'usure à grande avance.
- Carbure Submicrograin 0,2 µm.



d	Tolleranza/Tolérance
ø6 ~ 12	-0.005 ~ -0.015 mm
ø16 ~ 20	-0.01 ~ -0.02 mm

List. p.94

Unità: mm

Numero d'Ordine Reference	D x R	L1	L	d	Numero d'Ordine Reference	D x R	L1	L	d
6RCU 060 005 060	6 X R0.5	12	60	6					
6RCU 060 005 080	6 X R0.5	12	80	6					
6RCU 060 010 060	6 X R1	12	60	6					
6RCU 060 010 080	6 X R1	12	80	6					
6RCU 080 005 060	8 X R0.5	16	60	8					
6RCU 080 005 090	8 X R0.5	16	90	8					
6RCU 080 010 060	8 X R1	16	60	8					
6RCU 080 010 090	8 X R1	16	90	8					
6RCU 080 020 060	8 X R2	16	60	8					
6RCU 080 020 090	8 X R2	16	90	8					
6RCU 100 005 070	10 X R0.5	20	70	10					
6RCU 100 005 100	10 X R0.5	20	100	10					
6RCU 100 010 070	10 X R1	20	70	10					
6RCU 100 010 100	10 X R1	20	100	10					
6RCU 100 020 070	10 X R2	20	70	10					
6RCU 100 020 100	10 X R2	20	100	10					
6RCU 120 005 080	12 X R0.5	25	80	12					
6RCU 120 005 110	12 X R0.5	25	110	12					
6RCU 120 010 080	12 X R1	25	80	12					
6RCU 120 010 110	12 X R1	25	110	12					
6RCU 120 020 080	12 X R2	25	80	12					
6RCU 120 020 110	12 X R2	25	110	12					
6RCU 160 005 160	16 X R0.5	35	160	16					
6RCU 160 005 200	16 X R0.5	35	200	16					
6RCU 160 010 160	16 X R1	35	160	16					
6RCU 160 010 200	16 X R1	35	200	16					
6RCU 160 015 160	16 X R1.5	35	160	16					
6RCU 160 015 200	16 X R1.5	35	200	16					
6RCU 160 020 160	16 X R2	35	160	16					
6RCU 160 020 200	16 X R2	35	200	16					
6RCU 200 005 150	20 X R0.5	40	150	20					
6RCU 200 005 200	20 X R0.5	40	200	20					
6RCU 200 010 150	20 X R1	40	150	20					
6RCU 200 010 200	20 X R1	40	200	20					
6RCU 200 015 150	20 X R1.5	40	150	20					
6RCU 200 015 200	20 X R1.5	40	200	20					
6RCU 200 020 150	20 X R2	40	150	20					
6RCU 200 020 200	20 X R2	40	200	20					

