

- Fresa per differenti applicazioni su vari materiali, grafite, ghisa e materiali non ferrosi.
- Ottimo rendimento e basso sforzo di taglio grazie al rivestimento ALTiN.
- Varie lunghezze per spallamenti profondi su grafite.
- Il materiale impegnato (Ultra Micrograna) permette varie applicazioni su materiali non ferrosi.
- Fraise pour applications sur différentes matières, graphite, fonte et matériaux non ferreux.
- Excellent contre l'usure rapide grâce au revêtement ALTiN.
- Gamme de longueurs importante pour plus de variante d'usinage.
- Carbure Submicrograin pour application sur matériaux non ferreux.



0.25 ~ 2.5R 3R ~ 6R 8R ~ 12.5R

List. p.128

d	Tolleranza/Tolérance
ø 0.5 ~ 5	+0 ~ -0.01 mm
ø 6 ~ 12	-0.005 ~ -0.015 mm
ø 16 ~ 25	-0.01 ~ -0.02 mm

Unità: mm

FOR GRAPHITE

Numero d'Ordine Reference	R x D	L1	L2	L	d	Numero d'Ordine Reference	R x D	L1	L2	L	d
2GBE 005 020 S04	0.25R X 0.5	2	-	50	4	2GBE 050 250 S06	2.5R X 5	25	-	90	6
2GBE 005 050 S04	0.25R X 0.5	2	5	50	4	2GBE 050 500 S06	2.5R X 5	25	50	110	6
2GBE 010 050 S04	0.5R X 1	5	-	60	4	2GBE 060 250 110	3R X 6	25	-	110	6
2GBE 010 050 S06	0.5R X 1	5	-	60	6	2GBE 060 300 150	3R X 6	30	-	150	6
2GBE 010 100 S04	0.5R X 1	5	10	60	4	2GBE 060 300 200	3R X 6	30	-	200	6
2GBE 010 100 S06	0.5R X 1	5	10	60	6	2GBE 060 300 220	3R X 6	30	-	220	6
2GBE 010 150 S04	0.5R X 1	5	15	60	4	2GBE 080 350 110	4R X 8	35	-	110	8
2GBE 010 200 S04	0.5R X 1	5	20	60	4	2GBE 080 400 150	4R X 8	40	-	150	8
2GBE 010 250 S04	0.5R X 1	5	25	70	4	2GBE 080 400 200	4R X 8	40	-	200	8
2GBE 010 300 S04	0.5R X 1	5	30	80	4	2GBE 080 400 220	4R X 8	40	-	220	8
2GBE 010 350 S04	0.5R X 1	5	35	80	4	2GBE 100 400 120	5R X 10	40	-	120	10
2GBE 010 400 S04	0.5R X 1	5	40	90	4	2GBE 100 450 150	5R X 10	45	-	150	10
2GBE 015 080 S06	0.75R X 1.5	8	-	60	6	2GBE 100 450 200	5R X 10	45	-	200	10
2GBE 015 100 S04	0.75R X 1.5	8	10	60	4	2GBE 100 450 230	5R X 10	45	-	230	10
2GBE 015 150 S04	0.75R X 1.5	8	15	60	4	2GBE 120 500 130	6R X 12	50	-	130	12
2GBE 015 150 S06	0.75R X 1.5	8	15	60	6	2GBE 120 500 150	6R X 12	50	-	150	12
2GBE 015 200 S04	0.75R X 1.5	8	20	60	4	2GBE 120 550 200	6R X 12	55	-	200	12
2GBE 015 250 S04	0.75R X 1.5	8	25	70	4	2GBE 120 550 250	6R X 12	55	-	250	12
2GBE 015 300 S04	0.75R X 1.5	8	30	80	4	2GBE 160 600 160	8R X 16	60	-	160	16
2GBE 015 350 S04	0.75R X 1.5	8	35	80	4	2GBE 160 650 200	8R X 16	65	-	200	16
2GBE 015 400 S04	0.75R X 1.5	8	40	90	4	2GBE 160 650 250	8R X 16	65	-	250	16
2GBE 020 100 S04	1R X 2	10	-	60	4	2GBE 160 700 320	8R X 16	70	-	320	16
2GBE 020 100 S06	1R X 2	10	-	70	6	2GBE 200 700 160	10R X 20	70	-	160	20
2GBE 020 150 S04	1R X 2	10	15	60	4	2GBE 200 750 200	10R X 20	75	-	200	20
2GBE 020 200 S04	1R X 2	10	20	60	4	2GBE 200 750 250	10R X 20	75	-	250	20
2GBE 020 200 S06	1R X 2	10	20	70	6	2GBE 200 900 320	10R X 20	90	-	320	20
2GBE 020 250 S04	1R X 2	10	25	70	4	2GBE 250 1000 250	12.5R X 25	100	-	250	25
2GBE 020 300 S04	1R X 2	10	30	80	4						
2GBE 020 350 S04	1R X 2	10	35	80	4						
2GBE 020 400 S04	1R X 2	10	40	90	4						
2GBE 020 500 S04	1R X 2	10	50	100	4						
2GBE 020 600 S04	1R X 2	10	60	100	4						
2GBE 025 200 S04	1.25R X 2.5	10	20	70	4						
2GBE 030 150 100	1.5R X 3	15	-	100	3						
2GBE 030 150 S06	1.5R X 3	15	-	70	6						
2GBE 030 200 S04	1.5R X 3	15	20	70	4						
2GBE 030 300 S04	1.5R X 3	15	30	80	4						
2GBE 030 300 S06	1.5R X 3	15	30	75	6						
2GBE 030 400 S04	1.5R X 3	15	40	90	4						
2GBE 030 400 S06	1.5R X 3	15	40	90	6						
2GBE 030 500 S04	1.5R X 3	15	50	100	4						
2GBE 030 600 S04	1.5R X 3	15	60	100	4						
2GBE 040 200 080	2R X 4	20	-	80	4						
2GBE 040 200 100	2R X 4	20	-	100	4						
2GBE 040 200 130	2R X 4	20	-	130	4						
2GBE 040 200 S06	2R X 4	20	-	75	6						
2GBE 040 350 S06	2R X 4	20	35	90	6						
2GBE 040 450 S06	2R X 4	20	45	100	6						
2GBE 050 250 100	2.5R X 5	25	-	100	5						
2GBE 050 250 130	2.5R X 5	25	-	130	5						

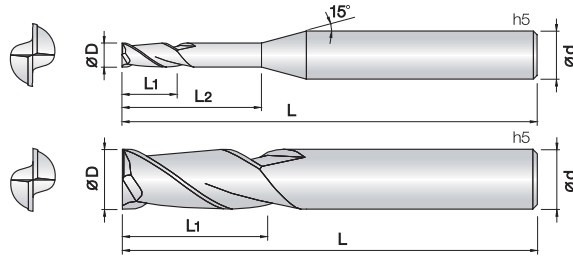

- Fresa per differenti applicazioni su vari materiali, grafite, ghisa e materiali non ferrosi.
- Ottimo rendimento e basso sforzo di taglio grazie al rivestimento ALTiN.
- Varie lunghezze per spallamenti profondi su grafite.
- Il materiale impegnato (Ultra Micrograna) permette varie applicazioni su acciai fino a HRc50.
- Fraise pour applications sur différentes matières, graphite, fonte et matériaux non ferreux.
- Excellent contre l'usure rapide grâce au revêtement ALTiN.
- Gamme de longueurs importante pour plus de variante d'usinage.
- Carbure Submicrograin pour application sur aciers jusqu'à 50HRc.



ø0.5 ~ 5

ø6 ~ 12

ø16 ~ 20

Rinforzato

List. p.129

d	Tolleranza/Tolérance
ø 0.5 ~ 5	+0 ~ -0.01 mm
ø 6 ~ 12	-0.01 ~ -0.025 mm
ø 16 ~ 20	-0.015 ~ -0.03 mm

Unità: mm

FOR GRAPHITE

Numero d'Ordine Reference	D	L1	L2	L	d	Numero d'Ordine Reference	D	L1	L2	L	d
2GEM 005 020 S04	0.5	2	-	50	4						
2GEM 010 050 S04	1	5	-	60	4						
2GEM 010 100 S04	1	5	10	60	4						
2GEM 010 100 S06	1	5	10	60	6						
2GEM 010 150 S04	1	5	15	60	4						
2GEM 010 200 S04	1	5	20	60	4						
2GEM 010 250 S04	1	5	25	70	4						
2GEM 015 100 S04	1.5	10	-	60	4						
2GEM 015 150 S04	1.5	8	15	60	4						
2GEM 015 200 S04	1.5	8	20	60	4						
2GEM 015 200 S06	1.5	8	20	60	6						
2GEM 015 250 S04	1.5	8	25	70	4						
2GEM 020 100 S04	2	10	-	60	4						
2GEM 020 150 S04	2	10	15	60	4						
2GEM 020 200 S04	2	10	20	60	4						
2GEM 020 200 S06	2	10	20	60	6						
2GEM 020 250 S04	2	10	25	70	4						
2GEM 020 300 S04	2	10	30	80	4						
2GEM 030 150 S04	3	15	-	70	4						
2GEM 030 250 S04	3	15	25	75	4						
2GEM 030 300 S06	3	15	30	75	6						
2GEM 040 200 100	4	20	-	100	4						
2GEM 040 400 S06	4	20	40	100	6						
2GEM 050 250 100	5	25	-	100	5						
2GEM 060 300 110	6	30	-	110	6						
2GEM 060 300 150	6	30	-	150	6						
2GEM 080 400 150	8	40	-	150	8						
2GEM 100 450 150	10	45	-	150	10						
2GEM 100 500 200	10	50	-	200	10						
2GEM 120 600 150	12	60	-	150	12						
2GEM 120 600 200	12	60	-	200	12						
2GEM 160 600 130	16	60	-	130	16						
2GEM 160 700 160	16	70	-	160	16						
2GEM 160 700 200	16	70	-	200	16						
2GEM 200 800 160	20	80	-	160	20						
2GEM 200 900 200	20	90	-	200	20						
2GEM 200 1200 320	20	120	-	320	20						

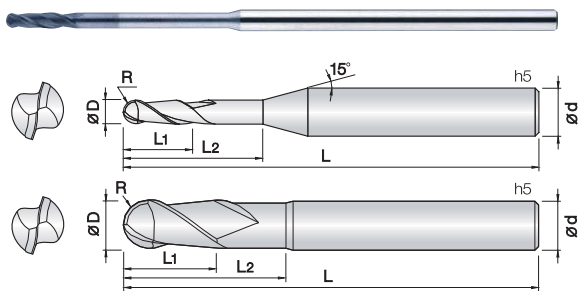

- Fresa per grafite, plastiche caricate, fibre di carbonio e materiali non ferrosi.
- Il nuovo rivestimento CVD Diamond garantisce un'eccellente resistenza all'usura.
- Ampia gamma di prodotti per le più svariate esigenze con rendimenti eccellenti.
- Fraise pour graphite, plastique chargé, fibre de carbone et métaux non ferreux.
- Excellent contre l'usure grâce au revêtement nouveau CVD Diamond.
- Gamme de produits important pour plus de variante d'usinage.



0.1 ~ 6R

List. p.131

d	Tolleranza/Tolérance
Ø 0.2 ~ 12	+0 ~ -0.02 mm

Unità: mm

Numero d'Ordine Reference	R x D	L1	L2	L	d	Numero d'Ordine Reference	R x D	L1	L2	L	d
2DBE 002 010 S04	0.1R X 0.2	1	-	45	4	2DBE 010 500 S04	0.5R X 1	3	50	80	4
2DBE 003 012 S04	0.15R X 0.3	1.2	-	45	4	2DBE 015 045 S04	0.75R X 1.5	4.5	-	60	4
2DBE 003 020 S04	0.15R X 0.3	1.2	2	45	4	2DBE 015 080 S04	0.75R X 1.5	4.5	8	80	4
2DBE 004 015 S04	0.2R X 0.4	1.5	-	45	4	2DBE 015 100 S04	0.75R X 1.5	4.5	10	80	4
2DBE 004 020 S04	0.2R X 0.4	1.5	2	45	4	2DBE 015 120 S04	0.75R X 1.5	4.5	12	80	4
2DBE 004 030 S04	0.2R X 0.4	1.5	3	45	4	2DBE 015 150 S04	0.75R X 1.5	4.5	15	80	4
2DBE 004 040 S04	0.2R X 0.4	1.5	4	45	4	2DBE 015 180 S04	0.75R X 1.5	4.5	18	80	4
2DBE 004 050 S04	0.2R X 0.4	1.5	5	45	4	2DBE 015 200 S04	0.75R X 1.5	4.5	20	80	4
2DBE 004 080 S04	0.2R X 0.4	1.5	8	45	4	2DBE 015 250 S04	0.75R X 1.5	4.5	25	80	4
2DBE 004 100 S04	0.2R X 0.4	1.5	10	45	4	2DBE 015 300 S04	0.75R X 1.5	4.5	30	80	4
2DBE 005 020 S04	0.25R X 0.5	2	-	45	4	2DBE 015 350 S04	0.75R X 1.5	4.5	35	80	4
2DBE 005 030 S04	0.25R X 0.5	2	3	45	4	2DBE 015 400 S04	0.75R X 1.5	4.5	40	80	4
2DBE 005 040 S04	0.25R X 0.5	2	4	45	4	2DBE 020 060 S04	1R X 2	6	-	60	4
2DBE 005 050 S04	0.25R X 0.5	2	5	45	4	2DBE 020 100 S04	1R X 2	6	10	80	4
2DBE 005 060 S04	0.25R X 0.5	2	6	45	4	2DBE 020 150 S04	1R X 2	6	15	80	4
2DBE 005 080 S04	0.25R X 0.5	2	8	45	4	2DBE 020 200 S04	1R X 2	6	20	80	4
2DBE 005 100 S04	0.25R X 0.5	2	10	45	4	2DBE 020 250 S04	1R X 2	6	25	80	4
2DBE 005 120 S04	0.25R X 0.5	2	12	45	4	2DBE 020 300 S04	1R X 2	6	30	80	4
2DBE 006 020 S04	0.3R X 0.6	2	-	45	4	2DBE 020 350 S04	1R X 2	6	35	80	4
2DBE 006 030 S04	0.3R X 0.6	2	3	45	4	2DBE 020 400 S04	1R X 2	6	40	100	4
2DBE 006 040 S04	0.3R X 0.6	2	4	45	4	2DBE 020 450 S04	1R X 2	6	45	100	4
2DBE 006 050 S04	0.3R X 0.6	2	5	45	4	2DBE 020 500 S04	1R X 2	6	50	100	4
2DBE 006 060 S04	0.3R X 0.6	2	6	45	4	2DBE 020 600 S04	1R X 2	6	60	100	4
2DBE 006 080 S04	0.3R X 0.6	2	8	45	4	2DBE 020 700 S04	1R X 2	6	70	100	4
2DBE 006 100 S04	0.3R X 0.6	2	10	45	4	2DBE 030 150 100	1.5R X 3	8	15	100	3
2DBE 006 120 S04	0.3R X 0.6	2	12	45	4	2DBE 030 080 S04	1.5R X 3	8	-	60	4
2DBE 006 150 S04	0.3R X 0.6	2	15	45	4	New 2DBE 030 080 S06	1.5R X 3	3	8	60	6
2DBE 006 200 S04	0.3R X 0.6	2	20	45	4	2DBE 030 150 S04	1.5R X 3	8	15	100	4
2DBE 008 030 S04	0.4R X 0.8	3	-	45	4	2DBE 030 200 S04	1.5R X 3	8	20	100	4
2DBE 008 040 S04	0.4R X 0.8	3	4	45	4	2DBE 030 250 S04	1.5R X 3	8	25	100	4
2DBE 008 050 S04	0.4R X 0.8	3	5	45	4	2DBE 030 300 S04	1.5R X 3	8	30	100	4
2DBE 008 060 S04	0.4R X 0.8	3	6	45	4	2DBE 030 350 S04	1.5R X 3	8	35	100	4
2DBE 008 080 S04	0.4R X 0.8	3	8	45	4	2DBE 030 400 S04	1.5R X 3	8	40	100	4
2DBE 008 100 S04	0.4R X 0.8	3	10	45	4	2DBE 030 500 S04	1.5R X 3	8	50	100	4
2DBE 008 150 S04	0.4R X 0.8	3	15	45	4	2DBE 030 600 S04	1.5R X 3	8	60	100	4
2DBE 008 200 S04	0.4R X 0.8	3	20	45	4	2DBE 030 700 S04	1.5R X 3	8	70	100	4
2DBE 010 030 S04	0.5R X 1	3	-	60	4	2DBE 040 040 060	2R X 4	4	-	60	4
2DBE 010 040 S04	0.5R X 1	3	4	60	4	2DBE 040 160 060	2R X 4	16	-	60	4
2DBE 010 050 S04	0.5R X 1	3	5	60	4	2DBE 040 160 080	2R X 4	16	-	80	4
2DBE 010 060 S04	0.5R X 1	3	6	60	4	2DBE 040 300 080	2R X 4	16	30	80	4
2DBE 010 080 S04	0.5R X 1	3	8	60	4	2DBE 040 160 100	2R X 4	16	-	100	4
2DBE 010 100 S04	0.5R X 1	3	10	60	4	2DBE 040 400 100	2R X 4	16	40	100	4
2DBE 010 120 S04	0.5R X 1	3	12	60	4	2DBE 040 160 130	2R X 4	16	-	130	4
2DBE 010 150 S04	0.5R X 1	3	15	60	4	2DBE 040 400 130	2R X 4	16	40	130	4
2DBE 010 200 S04	0.5R X 1	3	20	60	4	2DBE 040 160 150	2R X 4	16	-	150	4
2DBE 010 250 S04	0.5R X 1	3	25	80	4	2DBE 040 500 150	2R X 4	16	50	150	4
2DBE 010 300 S04	0.5R X 1	3	30	80	4	2DBE 050 160 110	2.5R X 5	16	-	110	5
2DBE 010 350 S04	0.5R X 1	3	35	80	4	2DBE 050 400 110	2.5R X 5	16	40	110	5
2DBE 010 400 S04	0.5R X 1	3	40	80	4	2DBE 050 200 S06	2.5R X 5	16	20	110	6
2DBE 010 450 S04	0.5R X 1	3	45	80	4	2DBE 050 400 S06	2.5R X 5	16	40	110	6

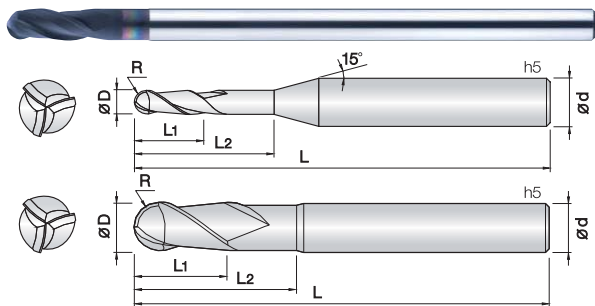

- Fresa per grafite, plastiche caricate, fibre di carbonio e materiali non ferrosi.
- Il nuovo rivestimento CVD Diamond garantisce un'eccellente resistenza all'usura.
- Ampia gamma di prodotti per le più svariate esigenze con rendimenti eccellenti.
- *Fraise pour graphite, plastique chargé, fibre de carbone et métaux non ferreux.*
- *Excellent contre l'usure grâce au revêtement nouveau CVD Diamant.*
- *Gamme de produits important pour plus de variante d'usinage.*

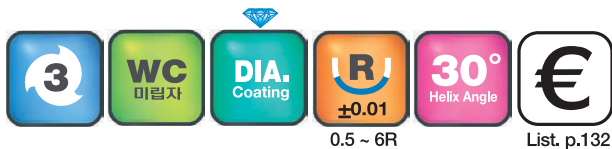

0.5 ~ 6R

List. p.132

d	Tolleranza/Tolérance
Ø1 ~ 12	+0 ~ -0.02 mm

Unità: mm

Numero d'Ordine Reference	R x D	L1	L2	L	d	Numero d'Ordine Reference	R x D	L1	L2	L	d
3DBE 010 030 S04	0.5R X 1	3	-	60	4	3DBE 060 500 150	3R X 6	16	50	150	6
3DBE 010 050 S04	0.5R X 1	3	5	60	4	3DBE 060 500 180	3R X 6	16	50	180	6
3DBE 010 100 S04	0.5R X 1	3	10	60	4	3DBE 080 400 110	4R X 8	20	40	110	8
3DBE 010 150 S04	0.5R X 1	3	15	60	4	3DBE 080 500 150	4R X 8	20	50	150	8
3DBE 010 200 S04	0.5R X 1	3	20	60	4	3DBE 100 400 110	5R X 10	22	40	110	10
3DBE 010 250 S04	0.5R X 1	3	25	80	4	3DBE 100 600 160	5R X 10	22	60	160	10
3DBE 010 300 S04	0.5R X 1	3	30	80	4	3DBE 120 500 110	6R X 12	25	50	110	12
3DBE 010 350 S04	0.5R X 1	3	35	80	4	3DBE 120 500 160	6R X 12	25	50	160	12
3DBE 010 400 S04	0.5R X 1	3	40	80	4	3DBE 120 600 200	6R X 12	25	60	200	12
3DBE 010 450 S04	0.5R X 1	3	45	80	4						
3DBE 010 500 S04	0.5R X 1	3	50	80	4						
3DBE 015 045 S04	0.75R X 1.5	4.5	-	60	4						
3DBE 015 100 S04	0.75R X 1.5	4.5	10	80	4						
3DBE 015 150 S04	0.75R X 1.5	4.5	15	80	4						
3DBE 015 200 S04	0.75R X 1.5	4.5	20	80	4						
3DBE 015 250 S04	0.75R X 1.5	4.5	25	80	4						
3DBE 015 300 S04	0.75R X 1.5	4.5	30	80	4						
3DBE 015 350 S04	0.75R X 1.5	4.5	35	80	4						
3DBE 015 400 S04	0.75R X 1.5	4.5	40	80	4						
3DBE 015 450 S04	0.75R X 1.5	4.5	45	80	4						
3DBE 015 500 S04	0.75R X 1.5	4.5	50	80	4						
3DBE 020 060 S04	1R X 2	6	-	60	4						
3DBE 020 100 S04	1R X 2	6	10	80	4						
3DBE 020 150 S04	1R X 2	6	15	80	4						
3DBE 020 200 S04	1R X 2	6	20	80	4						
3DBE 020 250 S04	1R X 2	6	25	80	4						
3DBE 020 300 S04	1R X 2	6	30	80	4						
3DBE 020 350 S04	1R X 2	6	35	80	4						
3DBE 020 400 S04	1R X 2	6	40	100	4						
3DBE 020 500 S04	1R X 2	6	50	100	4						
3DBE 020 600 S04	1R X 2	6	60	100	4						
3DBE 020 700 S04	1R X 2	6	70	100	4						
3DBE 030 150 100	1.5R X 3	8	15	100	3						
3DBE 030 080 S04	1.5R X 3	8	-	60	4						
3DBE 030 150 S04	1.5R X 3	8	15	100	4						
3DBE 030 200 S04	1.5R X 3	8	20	100	4						
3DBE 030 300 S04	1.5R X 3	8	30	100	4						
3DBE 030 400 S04	1.5R X 3	8	40	100	4						
3DBE 030 500 S04	1.5R X 3	8	50	100	4						
3DBE 040 160 080	2R X 4	16	-	80	4						
3DBE 040 300 080	2R X 4	16	30	80	4						
3DBE 040 160 100	2R X 4	16	-	100	4						
3DBE 040 400 100	2R X 4	16	40	100	4						
3DBE 040 160 130	2R X 4	16	-	130	4						
3DBE 040 400 130	2R X 4	16	40	130	4						
3DBE 050 160 110	2.5R X 5	16	-	110	5						
3DBE 050 400 110	2.5R X 5	16	40	110	5						
3DBE 060 250 110	3R X 6	16	25	110	6						
3DBE 060 400 110	3R X 6	16	40	110	6						
3DBE 060 300 150	3R X 6	16	30	150	6						



Fraise Hémisphérique 3 Coupes Diamant

Fresa Emisferica 3 Tagli Rastremata Diamond

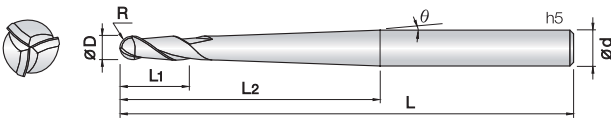

- Fresa per grafite, plastiche caricate, fibre di carbonio e materiali non ferrosi.
- Il nuovo rivestimento CVD Diamond garantisce un'eccellente resistenza all'usura.
- Ampia gamma di prodotti per le più svariate esigenze con rendimenti eccellenti.
- Fraise pour graphite, plastique chargé, fibre de carbone et métaux non ferreux.
- Excellent contre l'usure grâce au revêtement nouveau CVD Diamant.
- Gamme de produits important pour plus de variante d'usinage.

3

WC

DIA.

IRJ

30°

€

0.5 ~ 6R List. p.133

d	Tolleranza/Tolérance
ø 1 ~ 4	+0 ~ -0.02 mm

FOR GRAPHITE

Numero d'Ordine Reference	R x D	Ø	L1	L2	L	d		Numero d'Ordine Reference	R x D	Ø	L1	L2	L	d		
3TBD 010 003 300	0.5R X 1	0°30	3	30	100	4										
3TBD 010 003 400	0.5R X 1	0°30	3	40	100	4										
3TBD 010 003 500	0.5R X 1	0°30	3	50	100	4										
3TBD 010 010 300	0.5R X 1	1°	3	30	100	4										
3TBD 010 010 400	0.5R X 1	1°	3	40	100	4										
3TBD 010 010 500	0.5R X 1	1°	3	50	100	4										
3TBD 010 010 600	0.5R X 1	1°	3	60	100	4										
3TBD 015 003 300	0.75R X 1.5	0°30	4	30	100	4										
3TBD 015 003 400	0.75R X 1.5	0°30	4	40	100	4										
3TBD 015 003 500	0.75R X 1.5	0°30	4	50	100	4										
3TBD 015 010 400	0.75R X 1.5	1°	4	40	100	4										
3TBD 015 010 500	0.75R X 1.5	1°	4	50	100	4										
3TBD 015 010 600	0.75R X 1.5	1°	4	60	100	4										
3TBD 020 003 400	1R X 2	0°30	5	40	130	4										
3TBD 020 003 500	1R X 2	0°30	5	50	130	4										
3TBD 020 003 600	1R X 2	0°30	5	60	130	4										
3TBD 020 010 500	1R X 2	1°	5	50	130	4										
3TBD 020 010 600	1R X 2	1°	5	60	130	4										
3TBD 020 010 700	1R X 2	1°	5	70	130	4										
3TBD 030 003 600	1.5R X 3	0°30	6	60	150	6										
3TBD 030 003 800	1.5R X 3	0°30	6	80	150	6										
3TBD 030 010 700	1.5R X 3	1°	6	70	150	6										
3TBD 030 010 900	1.5R X 3	1°	6	90	150	6										
3TBD 040 003 800	2R X 4	0°30	8	80	150	6										
3TBD 040 003 1000	2R X 4	0°30	8	100	150	6										
3TBD 040 010 1000	2R X 4	1°	8	100	150	6										

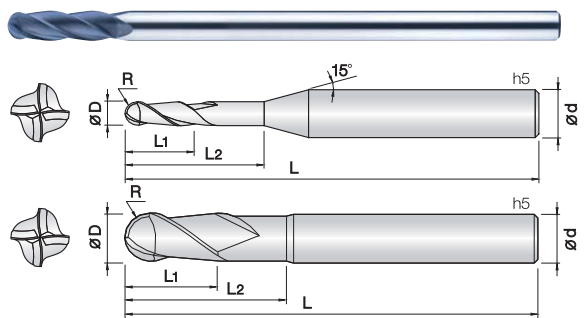

- Fresa per grafite, plastiche caricate, fibre di carbonio e materiali non ferrosi.
- Il nuovo rivestimento CVD Diamond garantisce un'eccellente resistenza all'usura.
- Ampia gamma di prodotti per le più svariate esigenze con rendimenti eccellenti.
- *Fraise pour graphite, plastique chargé, fibre de carbone et métaux non ferreux.*
- *Excellent contre l'usure grâce au revêtement nouveau CVD Diamant.*
- *Gamme de produits important pour plus de variante d'usinage.*



0.5 ~ 6R

List. p.134

d	Tolleranza/Tolérance
ø1 ~ 12	+0 ~ -0.02 mm

Unità: mm

Numero d'Ordine Reference	R x D	L1	L2	L	d	Numero d'Ordine Reference	R x D	L1	L2	L	d
4DBE 010 030 S04	0.5R X 1	3	-	60	4	4DBE 100 400 160	5R X 10	22	40	160	10
4DBE 010 050 S04	0.5R X 1	3	5	60	4	4DBE 100 500 200	5R X 10	22	50	200	10
4DBE 010 100 S04	0.5R X 1	3	10	60	4	4DBE 120 500 110	6R X 12	25	50	110	12
4DBE 010 150 S04	0.5R X 1	3	15	60	4	4DBE 120 500 160	6R X 12	25	50	160	12
4DBE 010 200 S04	0.5R X 1	3	20	60	4	4DBE 120 600 200	6R X 12	25	60	200	12
4DBE 010 250 S04	0.5R X 1	3	25	60	4						
4DBE 010 300 S04	0.5R X 1	3	30	80	4						
4DBE 010 350 S04	0.5R X 1	3	35	80	4						
4DBE 010 400 S04	0.5R X 1	3	40	80	4						
4DBE 010 450 S04	0.5R X 1	3	45	80	4						
4DBE 010 500 S04	0.5R X 1	3	50	80	4						
4DBE 015 045 S04	0.75R X 1.5	4.5	-	60	4						
4DBE 015 100 S04	0.75R X 1.5	4.5	10	60	4						
4DBE 015 150 S04	0.75R X 1.5	4.5	15	60	4						
4DBE 015 200 S04	0.75R X 1.5	4.5	20	60	4						
4DBE 015 250 S04	0.75R X 1.5	4.5	25	60	4						
4DBE 015 300 S04	0.75R X 1.5	4.5	30	80	4						
4DBE 015 350 S04	0.75R X 1.5	4.5	35	80	4						
4DBE 015 400 S04	0.75R X 1.5	4.5	40	80	4						
4DBE 015 450 S04	0.75R X 1.5	4.5	45	80	4						
4DBE 015 500 S04	0.75R X 1.5	4.5	50	80	4						
4DBE 020 060 S04	1R X 2	6	-	60	4						
4DBE 020 100 S04	1R X 2	6	10	80	4						
4DBE 020 200 S04	1R X 2	6	20	80	4						
4DBE 020 300 S04	1R X 2	6	30	80	4						
4DBE 020 400 S04	1R X 2	6	40	80	4						
4DBE 020 500 S04	1R X 2	6	50	100	4						
4DBE 020 600 S04	1R X 2	6	60	100	4						
4DBE 020 700 S04	1R X 2	6	70	100	4						
4DBE 030 080 S04	1.5R X 3	8	-	60	4						
4DBE 030 150 S04	1.5R X 3	8	15	100	4						
4DBE 030 200 S04	1.5R X 3	8	20	100	4						
4DBE 030 300 S04	1.5R X 3	8	30	100	4						
4DBE 030 400 S04	1.5R X 3	8	40	100	4						
4DBE 030 500 S04	1.5R X 3	8	50	100	4						
4DBE 030 600 S04	1.5R X 3	8	60	100	4						
4DBE 030 700 S04	1.5R X 3	8	70	100	4						
4DBE 040 160 060	2R X 4	16	-	60	4						
4DBE 040 160 080	2R X 4	16	-	80	4						
4DBE 040 160 100	2R X 4	16	-	100	4						
4DBE 040 160 130	2R X 4	16	-	130	4						
4DBE 060 250 080	3R X 6	16	25	80	6						
4DBE 060 250 110	3R X 6	16	25	110	6						
4DBE 060 300 150	3R X 6	16	30	150	6						
4DBE 080 300 080	4R X 8	20	30	80	8						
4DBE 080 300 110	4R X 8	20	30	110	8						
4DBE 080 350 150	4R X 8	20	35	150	8						
4DBE 080 400 200	4R X 8	20	40	200	8						
4DBE 100 350 080	5R X 10	22	35	80	10						
4DBE 100 350 110	5R X 10	22	35	110	10						

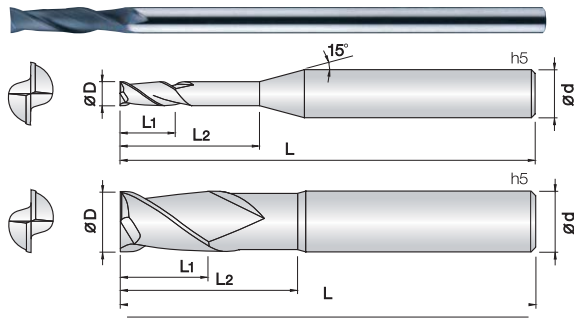

- Fresa per grafite, plastiche caricate, fibre di carbonio e materiali non ferrosi.
- Il nuovo rivestimento CVD Diamond garantisce un'eccellente resistenza all'usura.
- Ampia gamma di prodotti per le più svariate esigenze con rendimenti eccellenti.
- Fraise pour graphite, plastique chargé, fibre de carbone et métaux non ferreux.
- Excellent contre l'usure grâce au revêtement nouveau CVD Diamond.
- Gamme de produits important pour plus de variante d'usinage.



d	Tolleranza/Tolérance
ø0.2 ~ 12	+0 ~ -0.02mm

FOR GRAPHITE

Numero d'Ordine Reference	D	L1	L2	L	d	Numero d'Ordine Reference	D	L1	L2	L	d
2DEM 002 004 S04	0.2	0.4	-	45	4	2DEM 040 120 S06	4	12	-	50	6
2DEM 003 006 S04	0.3	0.6	-	45	4	2DEM 040 160 080	4	16	-	80	4
2DEM 003 020 S04	0.3	0.6	2	45	4	2DEM 050 150 S06	5	15	-	60	6
2DEM 003 040 S04	0.3	0.6	4	45	4	2DEM 050 200 S06	5	20	-	110	6
2DEM 004 008 S04	0.4	0.8	-	45	4	2DEM 060 180 S06	6	18	-	60	6
2DEM 004 020 S04	0.4	0.8	2	45	4	2DEM 060 250 110	6	25	-	110	6
2DEM 004 040 S04	0.4	0.8	4	45	4	2DEM 060 250 150	6	25	-	150	6
2DEM 005 010 S04	0.5	1	-	45	4	2DEM 080 240 S08	8	24	-	70	8
2DEM 005 030 S04	0.5	1	3	45	4	2DEM 080 400 150	8	25	40	150	8
2DEM 005 050 S04	0.5	1	5	45	4	2DEM 100 250 S10	10	25	-	80	10
2DEM 006 012 S04	0.6	1.2	-	45	4	2DEM 100 500 160	10	25	50	160	10
2DEM 006 030 S04	0.6	1.2	3	45	4	2DEM 120 250 S12	12	25	-	80	12
2DEM 006 050 S04	0.6	1.2	5	45	4	2DEM 120 600 160	12	25	60	160	12
2DEM 007 015 S04	0.7	1.5	-	45	4						
2DEM 007 040 S04	0.7	1.5	4	45	4						
2DEM 007 060 S04	0.7	1.5	6	45	4						
2DEM 007 080 S04	0.7	1.5	8	45	4						
2DEM 008 020 S04	0.8	2	-	45	4						
2DEM 009 025 S04	0.9	2.5	-	45	4						
2DEM 010 030 S04	1	3	-	60	4						
2DEM 010 030 045	1	3	-	45	4						
2DEM 010 050 S04	1	3	5	60	4						
2DEM 010 100 S04	1	3	10	60	4						
2DEM 010 150 S04	1	3	15	60	4						
2DEM 010 200 S04	1	3	20	60	4						
2DEM 010 250 S04	1	3	25	60	4						
2DEM 010 300 S04	1	3	30	60	4						
2DEM 015 060 S04	1.5	6	-	60	4						
2DEM 015 100 S04	1.5	6	10	60	4						
2DEM 015 150 S04	1.5	6	15	60	4						
2DEM 015 200 S04	1.5	6	20	60	4						
2DEM 015 250 S04	1.5	6	25	60	4						
2DEM 015 300 S04	1.5	6	30	60	4						
2DEM 020 060 S04	2	6	-	45	4						
2DEM 020 080 S04	2	8	-	80	4						
2DEM 020 120 S04	2	8	12	80	4						
2DEM 020 150 S04	2	8	15	80	4						
2DEM 020 200 S04	2	8	20	80	4						
2DEM 020 250 S04	2	8	25	80	4						
2DEM 020 300 S04	2	8	30	80	4						
2DEM 020 400 S04	2	8	40	80	4						
2DEM 020 450 S04	2	8	45	80	4						
2DEM 020 500 S04	2	8	50	80	4						
2DEM 030 090 S06	3	9	-	50	6						
2DEM 030 120 S04	3	12	-	80	4						
2DEM 030 200 S04	3	12	20	80	4						
2DEM 030 250 S04	3	12	25	80	4						
2DEM 030 300 S04	3	12	30	80	4						
2DEM 030 400 S04	3	12	40	80	4						
2DEM 030 500 S04	3	12	50	80	4						

Unità: mm

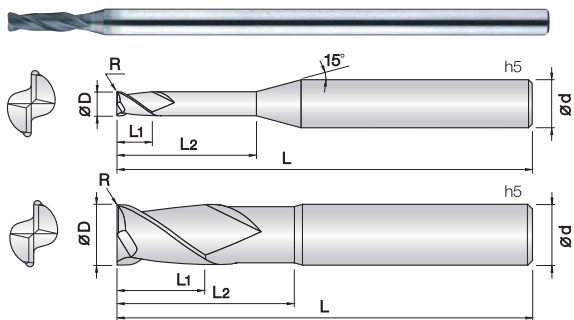

R0.02 ~ 1 List. p.136

- Fresa per grafite, plastiche caricate, fibre di carbonio e materiali non ferrosi.
- Il nuovo rivestimento CVD Diamond garantisce un'eccellente resistenza all'usura.
- Ampia gamma di prodotti per le più svariate esigenze con rendimenti eccellenti.
- *Fraise pour graphite, plastique chargé, fibre de carbone et métaux non ferreux.*
- *Excellent contre l'usure grâce au revêtement nouveau CVD Diamond.*
- *Gamme de produits important pour plus de variante d'usinage.*

d	Tolleranza/Tolerance
Ø0.2 ~ 6	+0 ~ -0.02 mm

Numero d'Ordine Reference	R x D	L1	L2	L	d	Numero d'Ordine Reference	R x D	L1	L2	L	d
2DCR 002 0002 015	0.2 X R0.02	0.5	1.5	60	4	2DCR 015 0015 030	1.5 X R0.15	3	-	60	4
2DCR 003 0002 015	0.3 X R0.02	0.6	1.5	60	4	2DCR 015 0015 050	1.5 X R0.15	3	5	60	4
2DCR 003 0002 030	0.3 X R0.02	0.6	3	60	4	2DCR 015 0015 100	1.5 X R0.15	3	10	60	4
2DCR 003 0002 045	0.3 X R0.02	0.6	4.5	60	4	2DCR 015 0015 150	1.5 X R0.15	3	15	60	4
2DCR 003 0002 060	0.3 X R0.02	0.6	6	60	4	2DCR 015 0015 200	1.5 X R0.15	3	20	60	4
2DCR 004 0002 020	0.4 X R0.02	0.8	2	60	4	2DCR 015 002 030	1.5 X R0.2	3	-	60	4
2DCR 004 0002 040	0.4 X R0.02	0.8	4	60	4	2DCR 015 002 050	1.5 X R0.2	3	5	60	4
2DCR 004 0002 060	0.4 X R0.02	0.8	6	60	4	2DCR 015 002 100	1.5 X R0.2	3	10	60	4
2DCR 004 0002 080	0.4 X R0.02	0.8	8	60	4	2DCR 015 002 150	1.5 X R0.2	3	15	60	4
2DCR 005 0005 010	0.5 X R0.05	1	-	60	4	2DCR 015 002 200	1.5 X R0.2	3	20	60	4
2DCR 005 0005 025	0.5 X R0.05	1	2.5	60	4	2DCR 015 003 030	1.5 X R0.3	3	-	60	4
2DCR 005 0005 035	0.5 X R0.05	1	3.5	60	4	2DCR 015 003 050	1.5 X R0.3	3	5	60	4
2DCR 005 0005 050	0.5 X R0.05	1	5	60	4	2DCR 015 003 100	1.5 X R0.3	3	10	60	4
2DCR 005 0005 075	0.5 X R0.05	1	7.5	60	4	2DCR 015 003 150	1.5 X R0.3	3	15	60	4
2DCR 005 0005 100	0.5 X R0.05	1	10	60	4	2DCR 015 003 200	1.5 X R0.3	3	20	60	4
2DCR 006 0005 012	0.6 X R0.05	1.2	-	60	4	2DCR 020 0005 035	2 X R0.05	3.5	-	60	4
2DCR 006 0005 030	0.6 X R0.05	1.2	3	60	4	2DCR 020 0005 060	2 X R0.05	3.5	6	60	4
2DCR 006 0005 060	0.6 X R0.05	1.2	6	60	4	2DCR 020 0005 120	2 X R0.05	3.5	12	60	4
2DCR 006 0005 090	0.6 X R0.05	1.2	9	60	4	2DCR 020 0005 180	2 X R0.05	3.5	18	60	4
2DCR 006 0005 120	0.6 X R0.05	1.2	12	60	4	2DCR 020 0005 250	2 X R0.05	3.5	25	60	4
2DCR 008 0005 016	0.8 X R0.05	1.6	-	60	4	2DCR 020 0005 300	2 X R0.05	3.5	30	60	4
2DCR 008 0005 040	0.8 X R0.05	1.6	4	60	4	2DCR 020 002 035	2 X R0.2	3.5	-	60	4
2DCR 008 0005 080	0.8 X R0.05	1.6	8	60	4	2DCR 020 002 060	2 X R0.2	3.5	6	60	4
2DCR 008 0005 100	0.8 X R0.05	1.6	10	60	4	2DCR 020 002 120	2 X R0.2	3.5	12	60	4
2DCR 008 0005 160	0.8 X R0.05	1.6	16	60	4	2DCR 020 002 180	2 X R0.2	3.5	18	60	4
2DCR 010 0005 020	1 X R0.05	2	-	60	4	2DCR 020 002 250	2 X R0.2	3.5	25	60	4
2DCR 010 0005 050	1 X R0.05	2	5	60	4	2DCR 020 002 300	2 X R0.2	3.5	30	60	4
2DCR 010 0005 100	1 X R0.05	2	10	60	4	2DCR 020 003 035	2 X R0.3	3.5	-	60	4
2DCR 010 0005 150	1 X R0.05	2	15	60	4	2DCR 020 003 060	2 X R0.3	3.5	6	60	4
2DCR 010 0005 200	1 X R0.05	2	20	60	4	2DCR 020 003 120	2 X R0.3	3.5	12	60	4
2DCR 010 001 020	1 X R0.1	2	-	60	4	2DCR 020 003 180	2 X R0.3	3.5	18	60	4
2DCR 010 001 050	1 X R0.1	2	5	60	4	2DCR 020 003 250	2 X R0.3	3.5	25	60	4
2DCR 010 001 100	1 X R0.1	2	10	60	4	2DCR 020 003 300	2 X R0.3	3.5	30	60	4
2DCR 010 001 150	1 X R0.1	2	15	60	4	2DCR 020 005 035	2 X R0.5	3.5	-	60	4
2DCR 010 001 200	1 X R0.1	2	20	60	4	2DCR 020 005 060	2 X R0.5	3.5	6	60	4
2DCR 010 002 020	1 X R0.2	2	-	60	4	2DCR 020 005 120	2 X R0.5	3.5	12	60	4
2DCR 010 002 050	1 X R0.2	2	5	60	4	2DCR 020 005 180	2 X R0.5	3.5	18	60	4
2DCR 010 002 100	1 X R0.2	2	10	60	4	2DCR 020 005 250	2 X R0.5	3.5	25	60	4
2DCR 010 002 150	1 X R0.2	2	15	60	4	2DCR 020 005 300	2 X R0.5	3.5	30	60	4
2DCR 010 002 200	1 X R0.2	2	20	60	4	2DCR 030 0005 040	3 X R0.05	4	-	80	4
2DCR 015 0005 030	1.5 X R0.05	3	-	60	4	2DCR 030 0005 100	3 X R0.05	4	10	80	4
2DCR 015 0005 050	1.5 X R0.05	3	5	60	4	2DCR 030 0005 200	3 X R0.05	4	20	80	4
2DCR 015 0005 100	1.5 X R0.05	3	10	60	4	2DCR 030 0005 300	3 X R0.05	4	30	80	4
2DCR 015 0005 150	1.5 X R0.05	3	15	60	4	2DCR 030 0005 400	3 X R0.05	4	40	80	4
2DCR 015 0005 200	1.5 X R0.05	3	20	60	4	2DCR 030 002 040	3 X R0.2	4	-	80	4
2DCR 015 001 030	1.5 X R0.1	3	-	60	4	2DCR 030 002 100	3 X R0.2	4	10	80	4
2DCR 015 001 050	1.5 X R0.1	3	5	60	4	2DCR 030 002 200	3 X R0.2	4	20	80	4
2DCR 015 001 100	1.5 X R0.1	3	10	60	4	2DCR 030 002 300	3 X R0.2	4	30	80	4
2DCR 015 001 150	1.5 X R0.1	3	15	60	4	2DCR 030 002 400	3 X R0.2	4	40	80	4
2DCR 015 001 200	1.5 X R0.1	3	20	60	4	2DCR 030 003 040	3 X R0.3	4	-	80	4

Unità: mm

Numero d'Ordine Reference	R x D	L1	L2	L	d		Numero d'Ordine Reference	R x D	L1	L2	L	d	
2DCR 030 003 100	3 X R0.3	4	10	80	4		2DCR 060 005 070	6 X R0.5	7	-	110	6	
2DCR 030 003 200	3 X R0.3	4	20	80	4		2DCR 060 005 200	6 X R0.5	7	20	110	6	
2DCR 030 003 300	3 X R0.3	4	30	80	4		2DCR 060 005 300	6 X R0.5	7	30	110	6	
2DCR 030 003 400	3 X R0.3	4	40	80	4		2DCR 060 005 500	6 X R0.5	7	50	110	6	
2DCR 030 005 040	3 X R0.5	4	-	80	4		2DCR 060 010 070	6 X R1	7	-	110	6	
2DCR 030 005 100	3 X R0.5	4	10	80	4		2DCR 060 010 200	6 X R1	7	20	110	6	
2DCR 030 005 200	3 X R0.5	4	20	80	4		2DCR 060 010 300	6 X R1	7	30	110	6	
2DCR 030 005 300	3 X R0.5	4	30	80	4		2DCR 060 010 500	6 X R1	7	50	110	6	
2DCR 030 005 400	3 X R0.5	4	40	80	4								
2DCR 030 010 040	3 X R1	4	-	80	4								
2DCR 030 010 100	3 X R1	4	10	80	4								
2DCR 030 010 200	3 X R1	4	20	80	4								
2DCR 030 010 300	3 X R1	4	30	80	4								
2DCR 030 010 400	3 X R1	4	40	80	4								
2DCR 040 0005 050	4 X R0.05	5	-	80	4								
2DCR 040 0005 150	4 X R0.05	5	15	80	4								
2DCR 040 0005 250	4 X R0.05	5	25	80	4								
2DCR 040 0005 400	4 X R0.05	5	40	80	4								
2DCR 040 002 050	4 X R0.2	5	-	80	4								
2DCR 040 002 150	4 X R0.2	5	15	80	4								
2DCR 040 002 250	4 X R0.2	5	25	80	4								
2DCR 040 002 400	4 X R0.2	5	40	80	4								
2DCR 040 005 050	4 X R0.5	5	-	80	4								
2DCR 040 005 150	4 X R0.5	5	15	80	4								
2DCR 040 005 250	4 X R0.5	5	25	80	4								
2DCR 040 005 400	4 X R0.5	5	40	80	4								
2DCR 040 010 050	4 X R1	5	-	80	4								
2DCR 040 010 150	4 X R1	5	15	80	4								
2DCR 040 010 250	4 X R1	5	25	80	4								
2DCR 040 010 400	4 X R1	5	40	80	4								
2DCR 050 0005 060	5 X R0.05	6	-	110	6								
2DCR 050 0005 150	5 X R0.05	6	15	110	6								
2DCR 050 0005 300	5 X R0.05	6	30	110	6								
2DCR 050 0005 500	5 X R0.05	6	50	110	6								
2DCR 050 002 060	5 X R0.2	6	-	110	6								
2DCR 050 002 150	5 X R0.2	6	15	110	6								
2DCR 050 002 300	5 X R0.2	6	30	110	6								
2DCR 050 002 500	5 X R0.2	6	50	110	6								
2DCR 050 005 060	5 X R0.5	6	-	110	6								
2DCR 050 005 150	5 X R0.5	6	15	110	6								
2DCR 050 005 300	5 X R0.5	6	30	110	6								
2DCR 050 005 500	5 X R0.5	6	50	110	6								
2DCR 060 0005 070	6 X R0.05	7	-	110	6								
2DCR 060 0005 200	6 X R0.05	7	20	110	6								
2DCR 060 0005 300	6 X R0.05	7	30	110	6								
2DCR 060 0005 500	6 X R0.05	7	50	110	6								
2DCR 060 002 070	6 X R0.2	7	-	110	6								
2DCR 060 002 200	6 X R0.2	7	20	110	6								
2DCR 060 002 300	6 X R0.2	7	30	110	6								
2DCR 060 002 500	6 X R0.2	7	50	110	6								

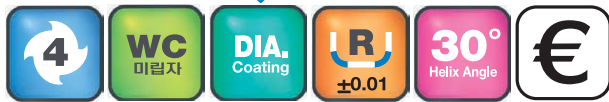
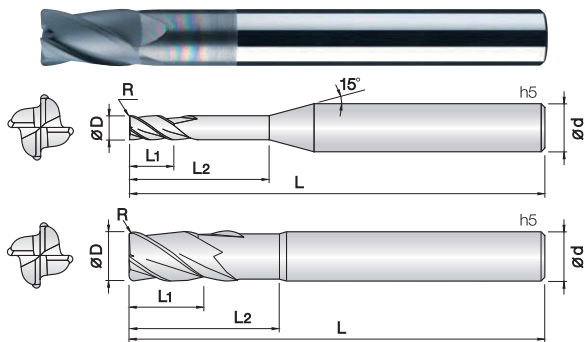

R0.05 - 1 List. p.138

- Fresa per grafite, plastiche caricate, fibre di carbonio e materiali non ferrosi.
- Il nuovo rivestimento CVD Diamond garantisce un'eccellente resistenza all'usura.
- Ampia gamma di prodotti per le più svariate esigenze con rendimenti eccellenti.
- *Fraise pour graphite, plastique chargé, fibre de carbone et métaux non ferreux.*
- *Excellent contre l'usure grâce au revêtement nouveau CVD Diamant.*
- *Gamme de produits important pour plus de variante d'usinage.*

d	Tolleranza/Tolérance
Ø0.2 ~ 6	+0 ~ -0.02 mm

Unità: mm

Numero d'Ordine Reference	R x D	L1	L2	L	d	Numero d'Ordine Reference	R x D	L1	L2	L	d
4DCR 020 0005 035	2 X R0.05	3.5	-	60	4	4DCR 040 005 100	4 X R0.5	6	20	100	4
4DCR 020 0005 060	2 X R0.05	3.5	6	60	4	4DCR 040 010 100	4 X R1	6	20	100	4
4DCR 020 0005 120	2 X R0.05	3.5	12	60	4	4DCR 060 003 110	6 X R0.3	9	25	110	6
4DCR 020 0005 180	2 X R0.05	3.5	18	60	4	4DCR 060 005 110	6 X R0.5	9	25	110	6
4DCR 020 0005 250	2 X R0.05	3.5	25	60	4	4DCR 060 005 150	6 X R0.5	9	30	150	6
4DCR 020 0005 300	2 X R0.05	3.5	30	60	4	4DCR 060 010 110	6 X R1	9	25	110	6
4DCR 020 002 035	2 X R0.2	3.5	-	60	4	4DCR 060 010 150	6 X R1	9	30	150	6
4DCR 020 002 060	2 X R0.2	3.5	6	60	4	4DCR 080 003 110	8 X R0.3	12	30	110	8
4DCR 020 002 120	2 X R0.2	3.5	12	60	4	4DCR 080 005 110	8 X R0.5	12	30	110	8
4DCR 020 002 180	2 X R0.2	3.5	18	60	4	4DCR 080 005 150	8 X R0.5	12	40	150	8
4DCR 020 002 250	2 X R0.2	3.5	25	60	4	4DCR 080 010 110	8 X R1	12	30	110	8
4DCR 020 002 300	2 X R0.2	3.5	30	60	4	4DCR 080 010 150	8 X R1	12	40	150	8
4DCR 020 003 035	2 X R0.3	3.5	-	60	4	4DCR 100 005 110	10 X R0.5	15	35	110	10
4DCR 020 003 060	2 X R0.3	3.5	6	60	4	4DCR 100 005 160	10 X R0.5	15	45	160	10
4DCR 020 003 120	2 X R0.3	3.5	12	60	4	4DCR 100 010 110	10 X R1	15	35	110	10
4DCR 020 003 180	2 X R0.3	3.5	18	60	4	4DCR 100 010 160	10 X R1	15	45	160	10
4DCR 020 003 250	2 X R0.3	3.5	25	60	4	4DCR 120 005 110	12 X R0.5	18	40	110	12
4DCR 020 003 300	2 X R0.3	3.5	30	60	4	4DCR 120 005 160	12 X R0.5	18	45	160	12
4DCR 020 005 035	2 X R0.5	3.5	-	60	4	4DCR 120 010 110	12 X R1	18	40	110	12
4DCR 020 005 060	2 X R0.5	3.5	6	60	4	4DCR 120 010 160	12 X R1	18	45	160	12
4DCR 020 005 120	2 X R0.5	3.5	12	60	4						
4DCR 020 005 180	2 X R0.5	3.5	18	60	4						
4DCR 020 005 250	2 X R0.5	3.5	25	60	4						
4DCR 020 005 300	2 X R0.5	3.5	30	60	4						
4DCR 030 0005 040	3 X R0.05	4	-	80	4						
4DCR 030 0005 100	3 X R0.05	4	10	80	4						
4DCR 030 0005 200	3 X R0.05	4	20	80	4						
4DCR 030 0005 300	3 X R0.05	4	30	80	4						
4DCR 030 0005 400	3 X R0.05	4	40	80	4						
4DCR 030 002 040	3 X R0.2	4	-	80	4						
4DCR 030 002 100	3 X R0.2	4	10	80	4						
4DCR 030 002 200	3 X R0.2	4	20	80	4						
4DCR 030 002 300	3 X R0.2	4	30	80	4						
4DCR 030 002 400	3 X R0.2	4	40	80	4						
4DCR 030 003 040	3 X R0.3	4	-	80	4						
4DCR 030 003 100	3 X R0.3	4	10	80	4						
4DCR 030 003 200	3 X R0.3	4	20	80	4						
4DCR 030 003 300	3 X R0.3	4	30	80	4						
4DCR 030 003 400	3 X R0.3	4	40	80	4						
4DCR 030 005 040	3 X R0.5	4	-	80	4						
4DCR 030 005 100	3 X R0.5	4	10	80	4						
4DCR 030 005 200	3 X R0.5	4	20	80	4						
4DCR 030 005 300	3 X R0.5	4	30	80	4						
4DCR 030 005 400	3 X R0.5	4	40	80	4						
4DCR 030 010 040	3 X R1	4	-	80	4						
4DCR 030 010 100	3 X R1	4	10	80	4						
4DCR 030 010 200	3 X R1	4	20	80	4						
4DCR 030 010 300	3 X R1	4	30	80	4						
4DCR 030 010 400	3 X R1	4	40	80	4						
4DCR 040 003 100	4 X R0.3	6	20	100	4						

FOR GRAPHITE